

Quick Installation Guide US Series Hybrid Inverter

1. Packing List

OBJ	QTY	DESC	OBJ	QTY	DESC
A	1	Inverter	F	1	Quick Installatoin Guide
B	1	Bracket	G	1	Smart WiLAN
C	4	Expansion Tube	H	1	E-STOP
D	4	Expansion Screw	I	1	FOX Hub
E	1	Set Screw			

1

2. Tools

2

3. Installation Steps

Inverter Installation

Please make sure the inverter will be installed with a proper distance as shown below.

Position	Min Size
Left	300mm (11.8in)
Right	300mm (11.8in)
Top	300mm (11.8in)
Bottom	300mm (11.8in)
Front	300mm (11.8in)

Step 1: Fix the bracket on the wall

3

Step 2: Match the inverter with wall bracket

FOX Hub Installation

Step 1: Fix the bracket on the wall

4

Step 2: Match the FOX Hub with wall bracket

5

Suggestion: the height difference between the highest installation holes of the FOX Hub bracket and the inverter bracket is 101.3mm.

6

US SERIES HYBRID INVERTER QUICK INSTALLATION GUIDE

4. Wiring Steps

System Wiring Diagram

Whole-Home Backup (DC Couple)

7

Whole-Home Backup (AC Couple)

8

Partial-Home Backup (DC Couple)

9

Partial-Home Backup (AC Couple)

10

FOX Hub Power Cable Wiring

FOX Hub Connection: Load Terminal

- L1: 6 AWG - 250 kcmil 11/4"
- L2: 6 AWG - 250 kcmil 11/4"
- N: 6 AWG - 250 kcmil 11/4"
- PE: 6 AWG - 2/0 3/4"

Partial Backup: to Subpanel
Whole-home Backup: to Main Panel

11

FOX Hub Connection: Grid Terminal

- L1: 6 AWG - 250 kcmil 11/4"
- L2: 6 AWG - 250 kcmil 11/4"
- N: 6 AWG - 250 kcmil 11/4"
- PE: 6 AWG - 2/0 3/4"

Partial Backup: to Main Panel
Whole-home Backup: to Utility Meter

12

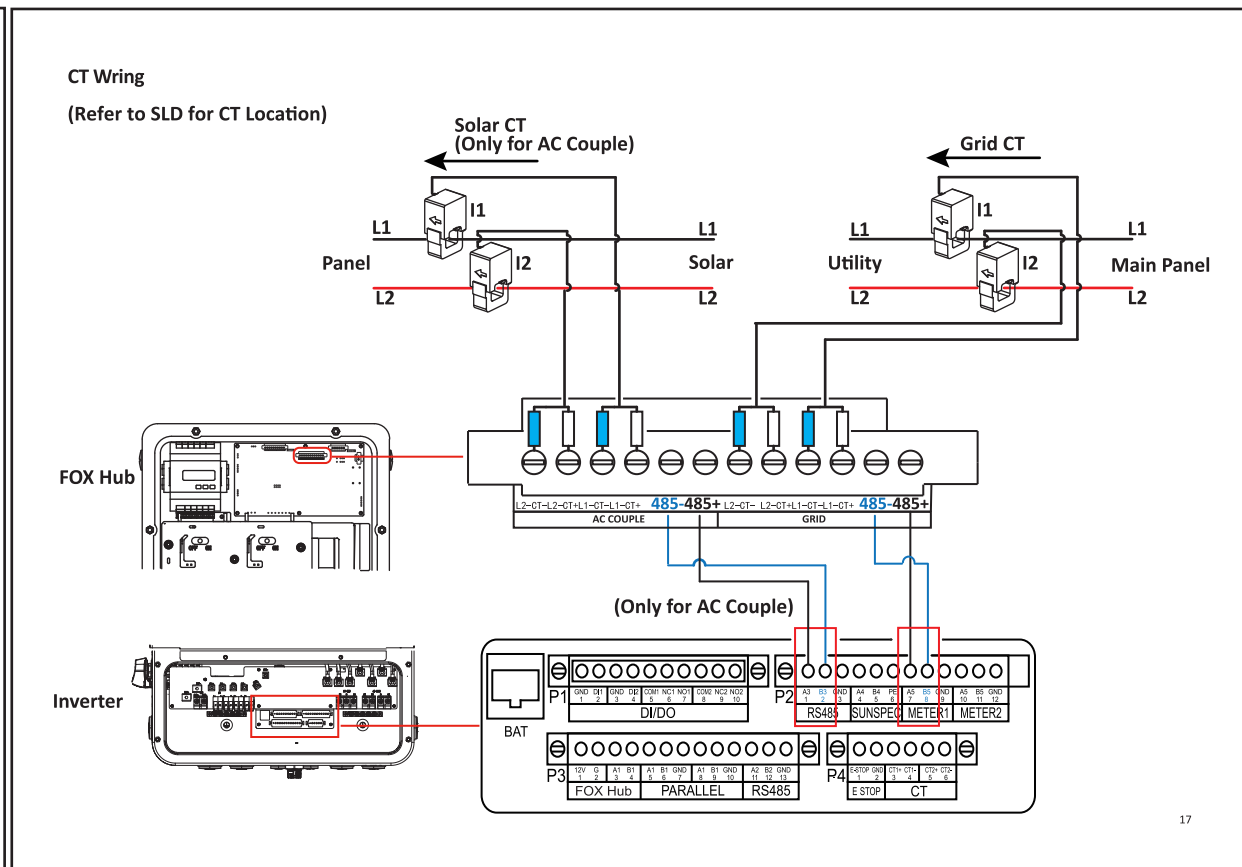
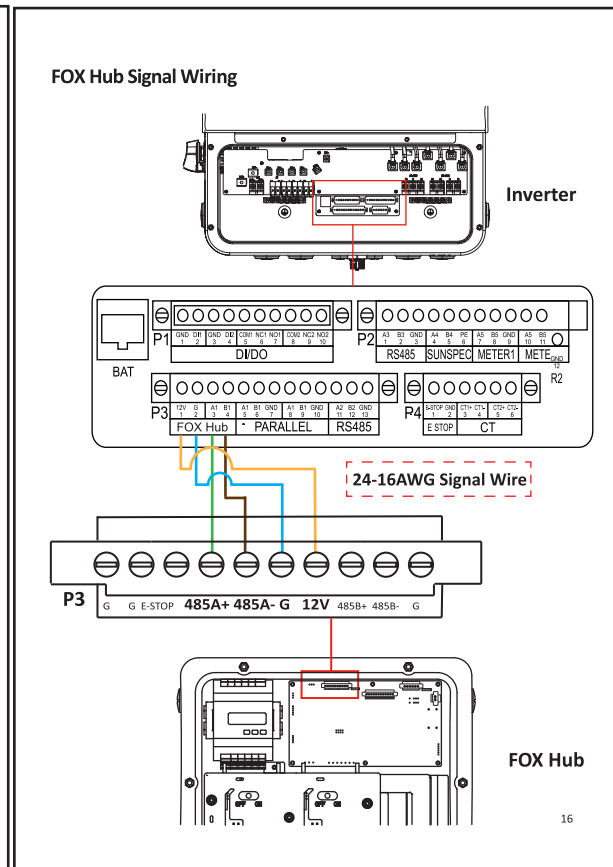
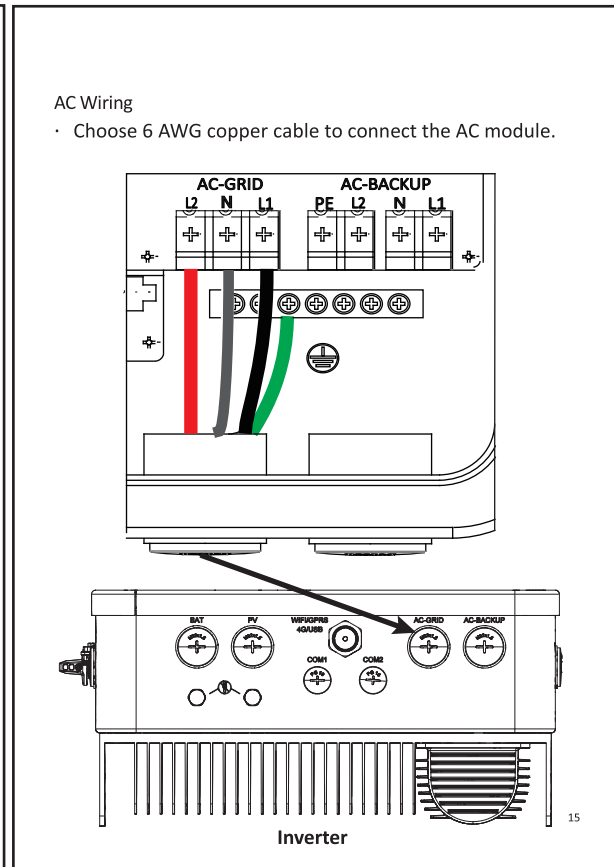
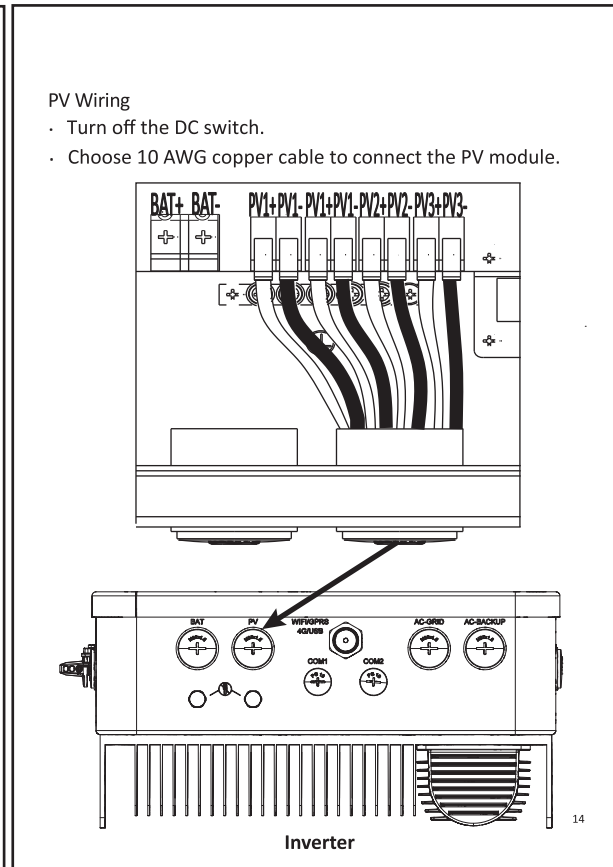
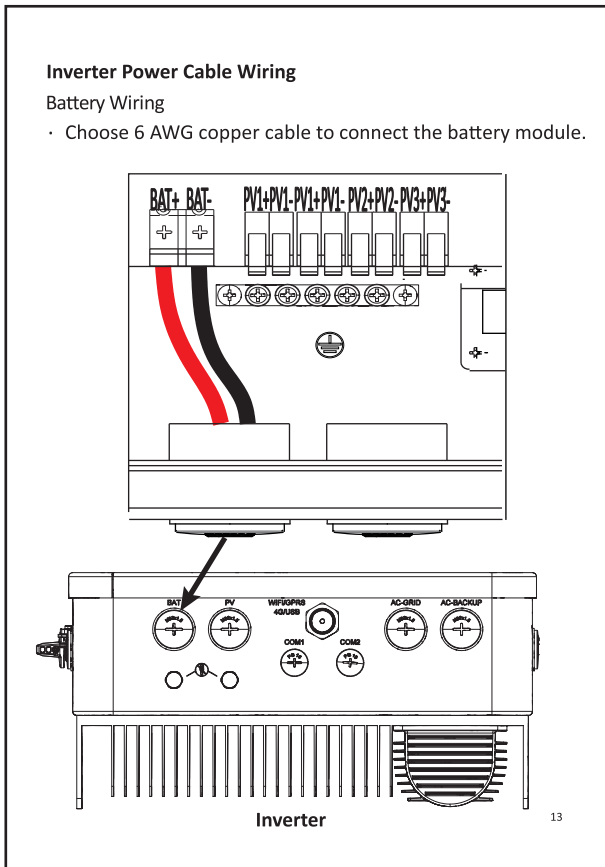

US SERIES HYBRID INVERTER QUICK INSTALLATION GUIDE

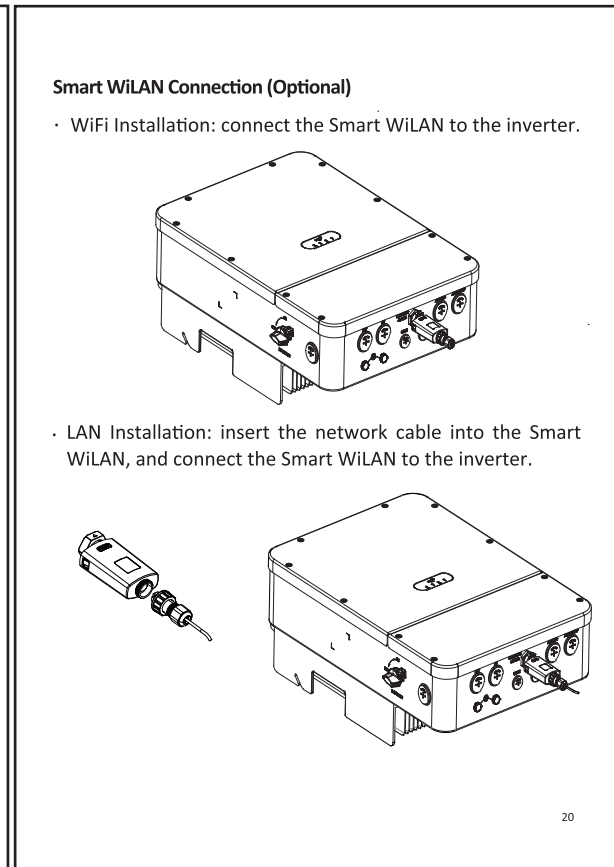
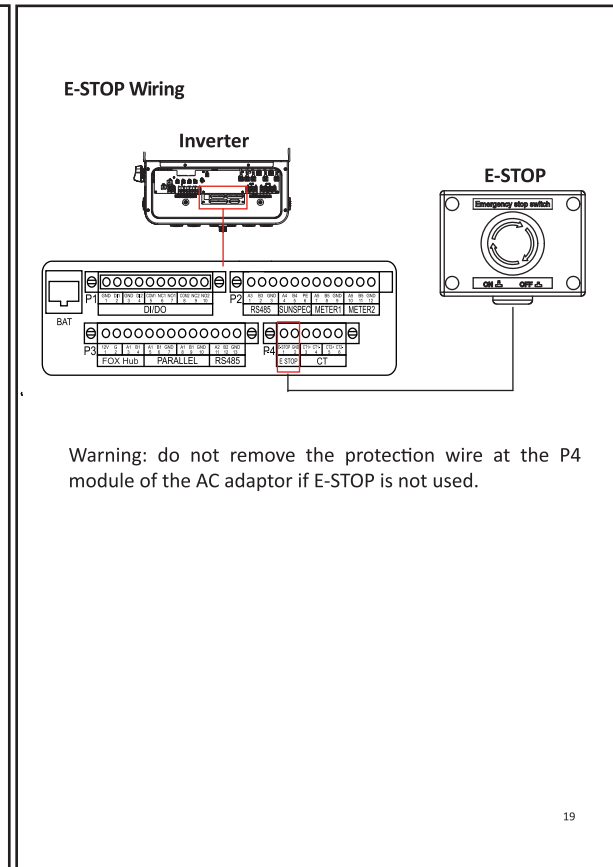
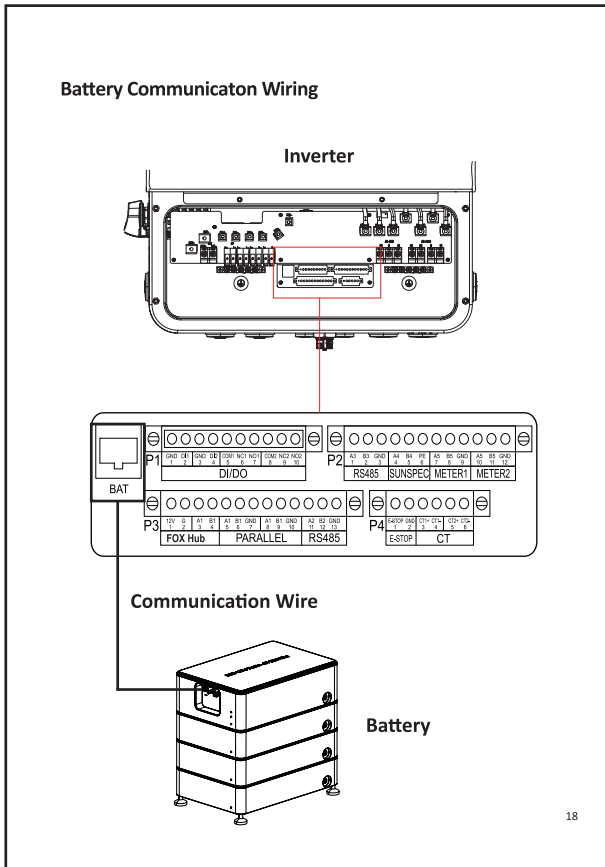

5. Inverter Switch On

Please refer to the following steps to switch on the inverter.

- Ensure the inverter is fixed properly on the wall.
- Ensure all cables are connected properly.
- Ensure the meter and external off-grid contactor are connected properly (if needed).
- Ensure the battery and E-STOP wires are connected properly.
- Turn on the PV/DC switch, battery, AC breaker, and off-grid breaker.
- For commissioning, please refer to quick installation guide for the Smart WiLAN (US).

In case you need to switch off the inverter, please refer to the following steps:

- Turn off the PV/DC switch, battery, AC breaker, and off-grid breaker.
- Wait 5 min before you open the upper cover (in case of repair).

The user manual will be updated frequently. For the latest version, please download it from the official website.