

# Whole-home Backup (DC Couple)

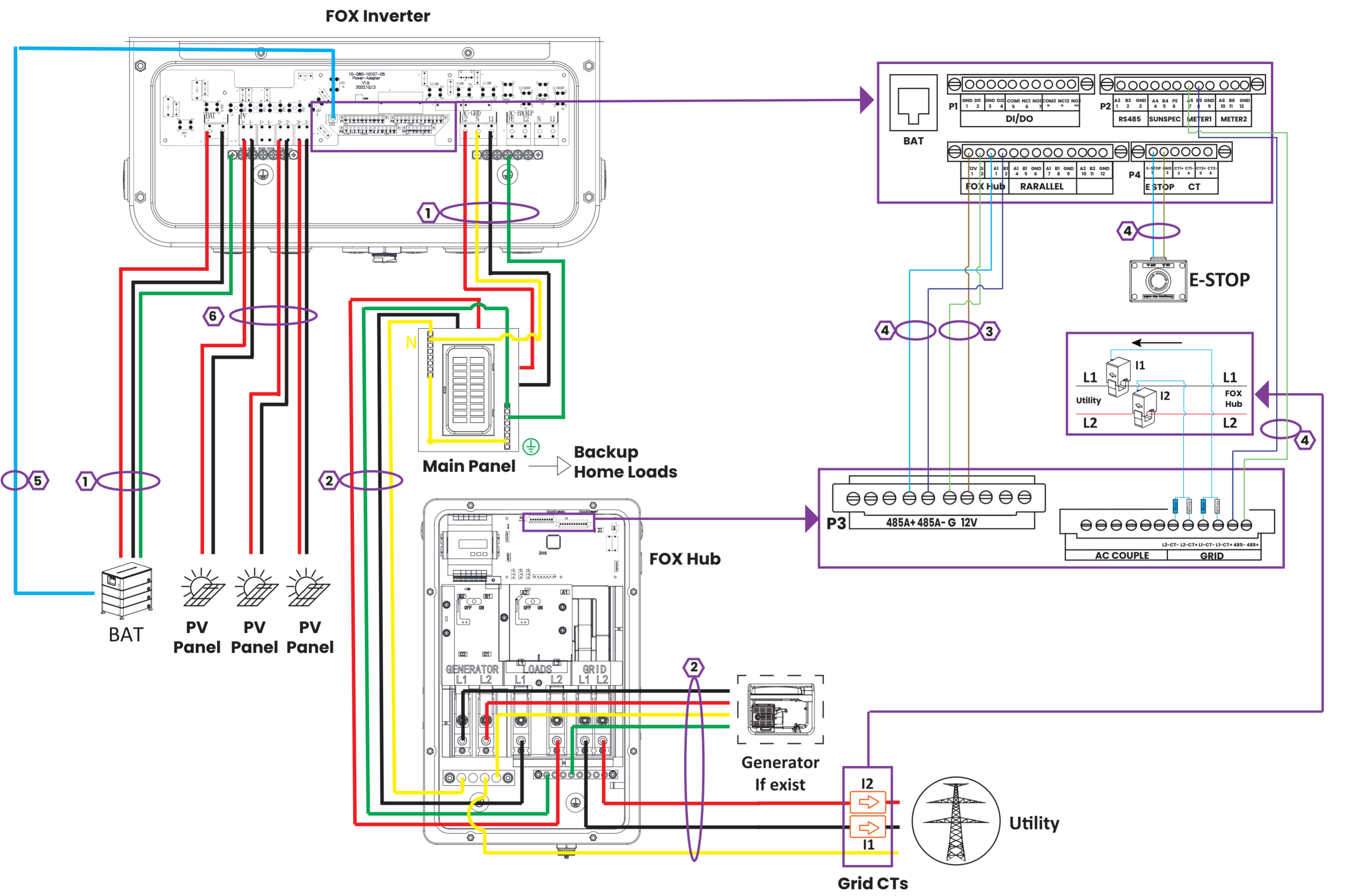

**Key**

- L1/Negative
- L2/Positive
- Ground
- Neutral

**Other Colors: Sensors/Communications**

**Current Sensors (CT) Key**

- ➡ L1
- ➡ L2

Wire Gauge Guide(copper)		
Label	Input Terminal	Conductor
1	BAT/AC IN/OUT/N/GND	6 AWG
2	AC IN/OUT/N/GND	6-2/0 AWG
3	Hub Power	16 AWG
4	Signal Cable	24-16 AWG
5	Communication Cable	Ethernet Cable
6	MPPT	10 AWG