

Fox PowerQ Energy Storage System

Quick Installation Guide

Issue: V1.0a

Date: 2024-04-01

FOXESS CO., LTD.



Notice

1. The information in this document may not be modified, copied or reproduced, in whole or in part, without the prior written permission of FOXESS CO., LTD. All information in this document is provided to the best of our knowledge and efforts, but does not constitute a warranty of any kind, express or implied. You can download quick guide and user manual by scanning the QR code.



2. Only certified electricians are allowed to operate the device. Operation personnel must wear proper personal protective equipment (PPE).
3. Before installing the device, check that the package contents are intact and complete against the packing list. If any damage is found or any component is missing, contact your dealer.
4. The device damage caused by the violation of instructions in this document is not covered under warranty.
5. The cable colors involved in this document are for reference only. Select cables in accordance with local cable specifications.
6. Fox PowerQ Energy Storage System has passed UL9540A unit level testing, suitable for residential indoor flooring installation

Testing Laboratory Name: CSA GROUP

Project Number: 80182817

Date of issue: April 2024

1 Packing List

1.1 Cube Inverter Package Box

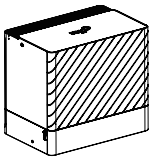

A



B

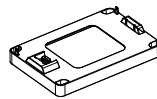

C



D

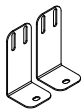

E



F



G



H



I

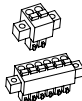

J

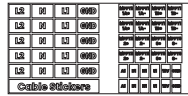

K



L

OBJ	QTY	DESC	OBJ	QTY	DESC
A	1	Cube Inverter	G	4	Expansion Tube & Expansion Screw
B	1	Side Cover	H	2	Handle
C	1	Base	I	2	Flat-head Screw
D	4	Set Screw	J	2	2-pin Socket & 6-pin Socket
E	2	Fixing Bracket	K	1	Cable Sticker
F	4	Sleeve Expansion Bolt M8*60	L	1	Quick Installation Guide

1.2 Battery Package Box

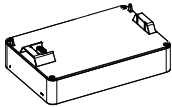

A



B

OBJ	QTY	DESC	OBJ	QTY	DESC
A	2-7	EQ4000	B	2	Set Screw

1.3 FOX Hub G2 Package Box



A

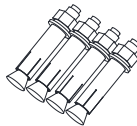

B



C



D

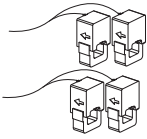

E



F



G

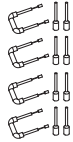

H

SUITABLE FOR USE AS
SERVICE EQUIPMENT ONLY
IN USA WHEN EQUIPPED
WITH MAIN BREAKER

SERVICE DISCONNECT

I

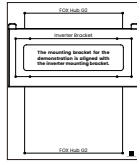

J

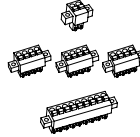

K

OBJ	QTY	DESC	OBJ	QTY	DESC
A	1	FOX Hub G2	G	1	E-STOP
B	4	Sleeve Expansion Bolt M8*60	H	4	120Ω Terminating Resistor
C	4	Waterproof Gasket	I	2	Label
D	1	Smart WiLAN & Smart 4GWiLAN	J	1	Installation Paperboard
E	4	250A Current Transformer	K	5	2-pin Socket & 4-pin Socket & 9-pin Socket
F	1	100A Current Transformer			

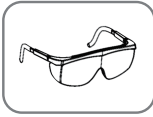

Safety Goggles



Steel Toe Boots

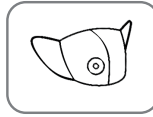

Dust Mask



Helmet



Insulating Gloves

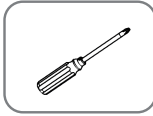

Phillips-Head Screwdriver

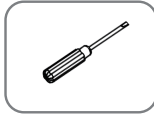

Flat-Head Screwdriver

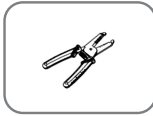

Wire Stripper



Electric Drill



Adjustable Wrench

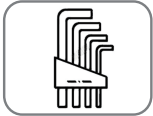

Hex Wrench Set



Hole Punch

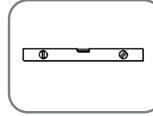

Level



Tape

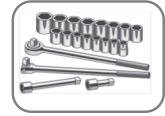

Sleeve



Multimeter



Phone



DANGER:

Special care must be taken to protect personal safety.

PPE must be worn during transfer and installation.



WARNING:

Please use proper protective measures, such as foam or protective cloth, keep the equipment well protected from hard objects that may damage their exterior appearance or body during handling and installation.

3.1 Installation Environment

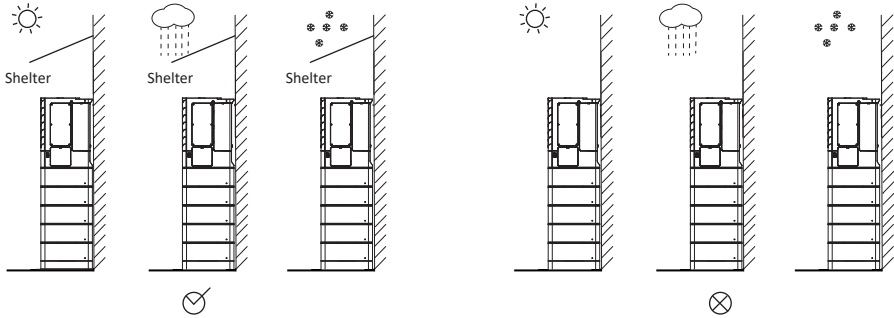

3.2 System Installation Space

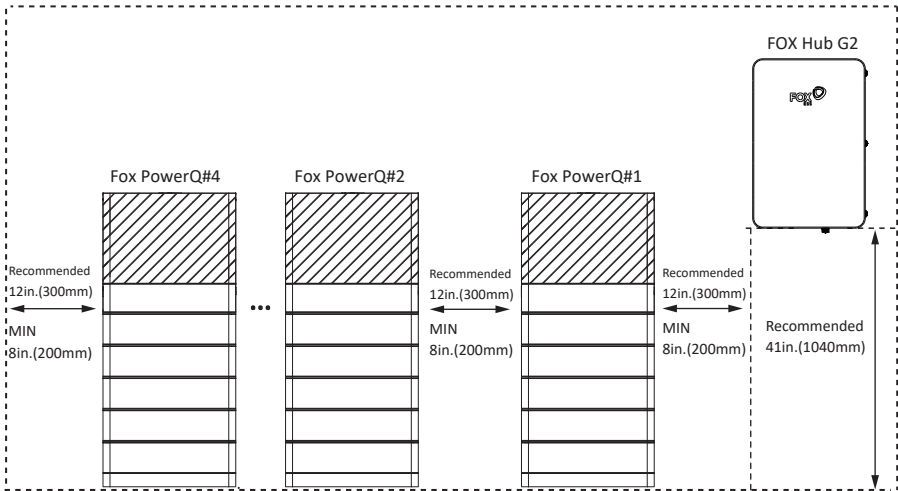

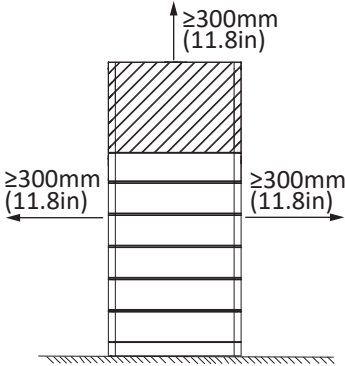

3.3 Fox PowerQ Installation

Space

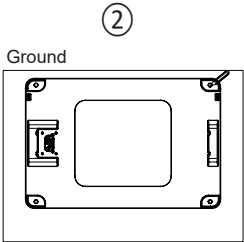
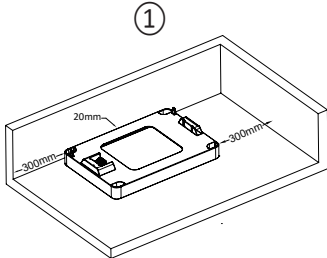

Steps



 The base needs to be more than 20mm against the wall.

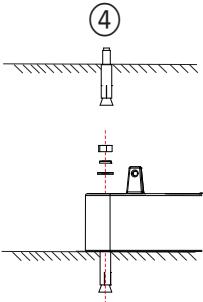
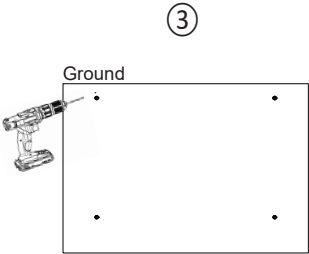

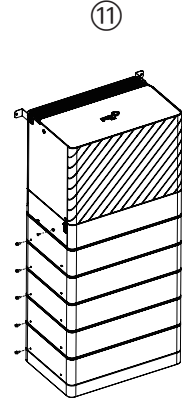
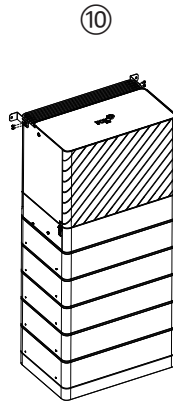
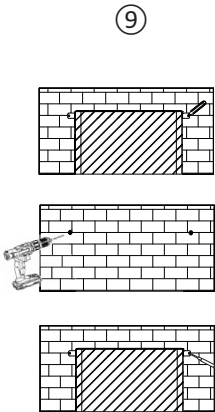
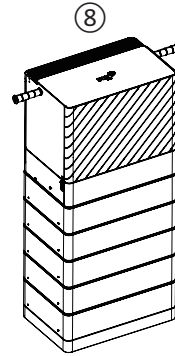
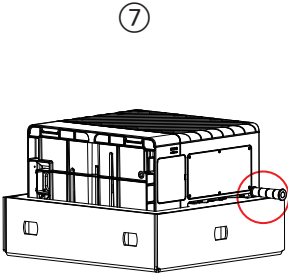
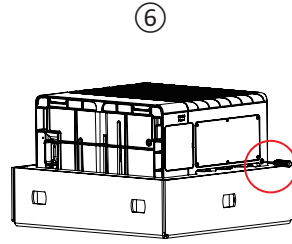
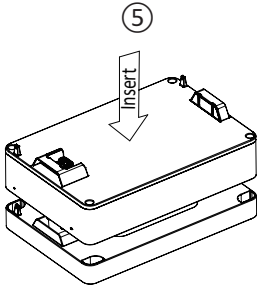

3.4 FOX Hub G2 Installation

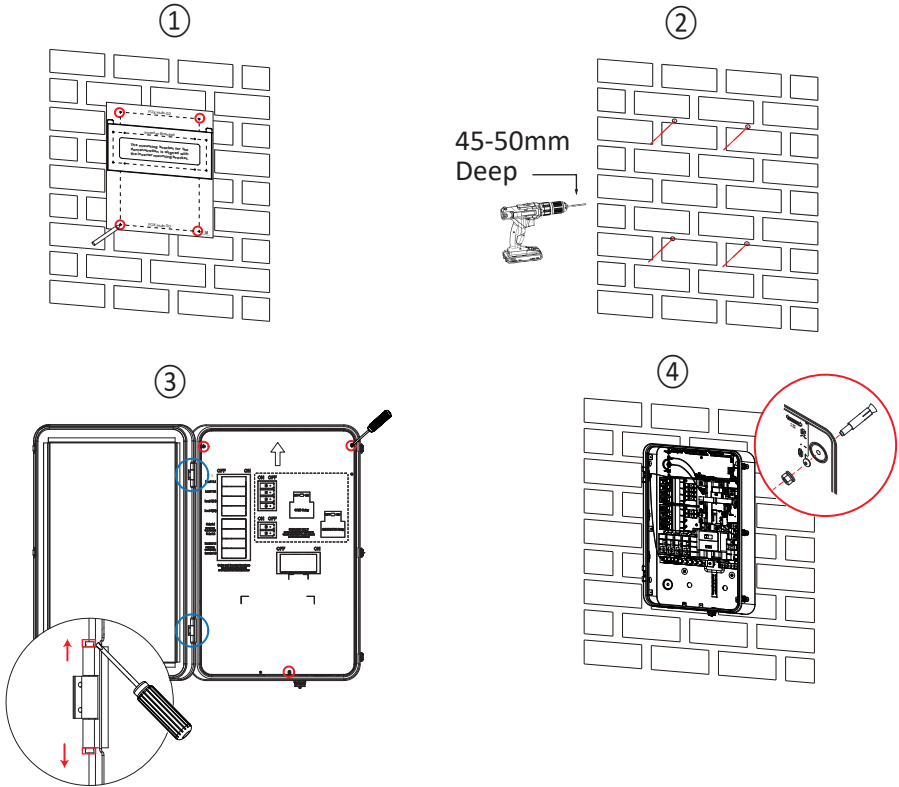

4 System Wiring Diagram

Note: ① In a parallel connection mode, the paralleled inverters need to be of the same model, and the batteries also need to be of the same model and capacity.

② The FOX Hub G2 may not come with the capability to connect to smart circuit and generator. Please refer to the checkmarks on the shipping mark of the FOX Hub G2. If "smart circuit" or "generator" is checked, the FOX Hub G2 comes with the corresponding functions.

FOX Hub		
MODEL: FOX Hub G2		
Date: 22W01	G.W: 23kg(51lb)	N.W: 18kg(40lb)
Dimension(mm): 760(W)×540(H)×276(D)		
Factory Certification: ISO9001:2015 Safety/EMC Certification		
<input type="checkbox"/> WILAN	<input type="checkbox"/> G4WILAN	<input type="checkbox"/> GENERATOR
<input type="checkbox"/> SMART CIRCUIT		
PIN: 30-403-00002-00		
S/N:		MADE IN CHINA
60AT2530211A002		

Shipping Mark

4.1 Whole-home Backup

Whole-home Backup (DC Couple)

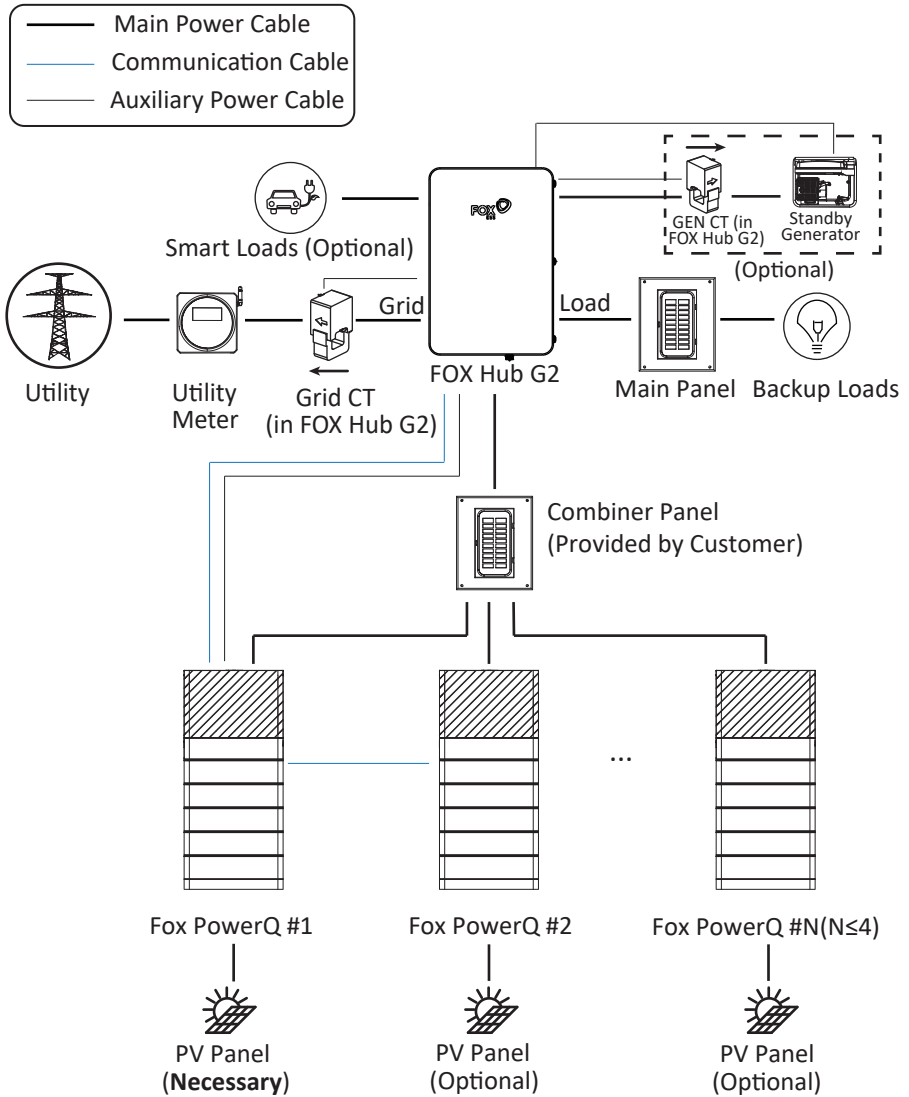

Whole-home Backup (AC Couple)

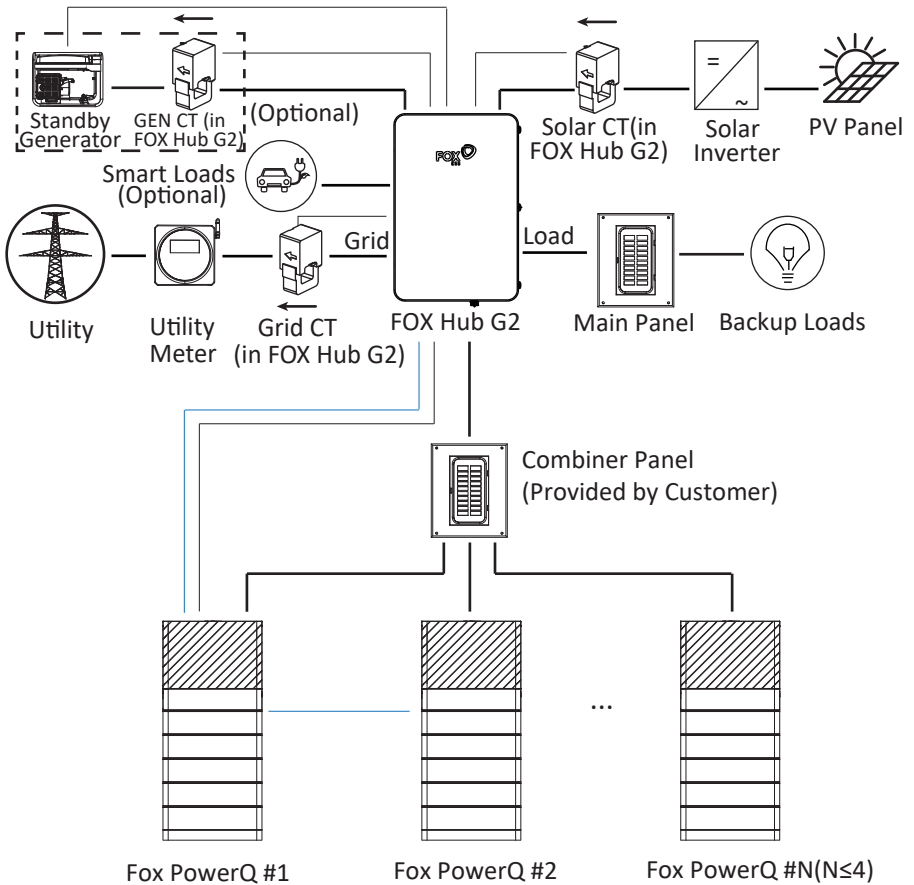
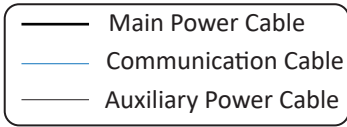

4.2 Partial-home Backup

Partial-home Backup (DC Couple) (FOX Hub G2 as Service Panel)

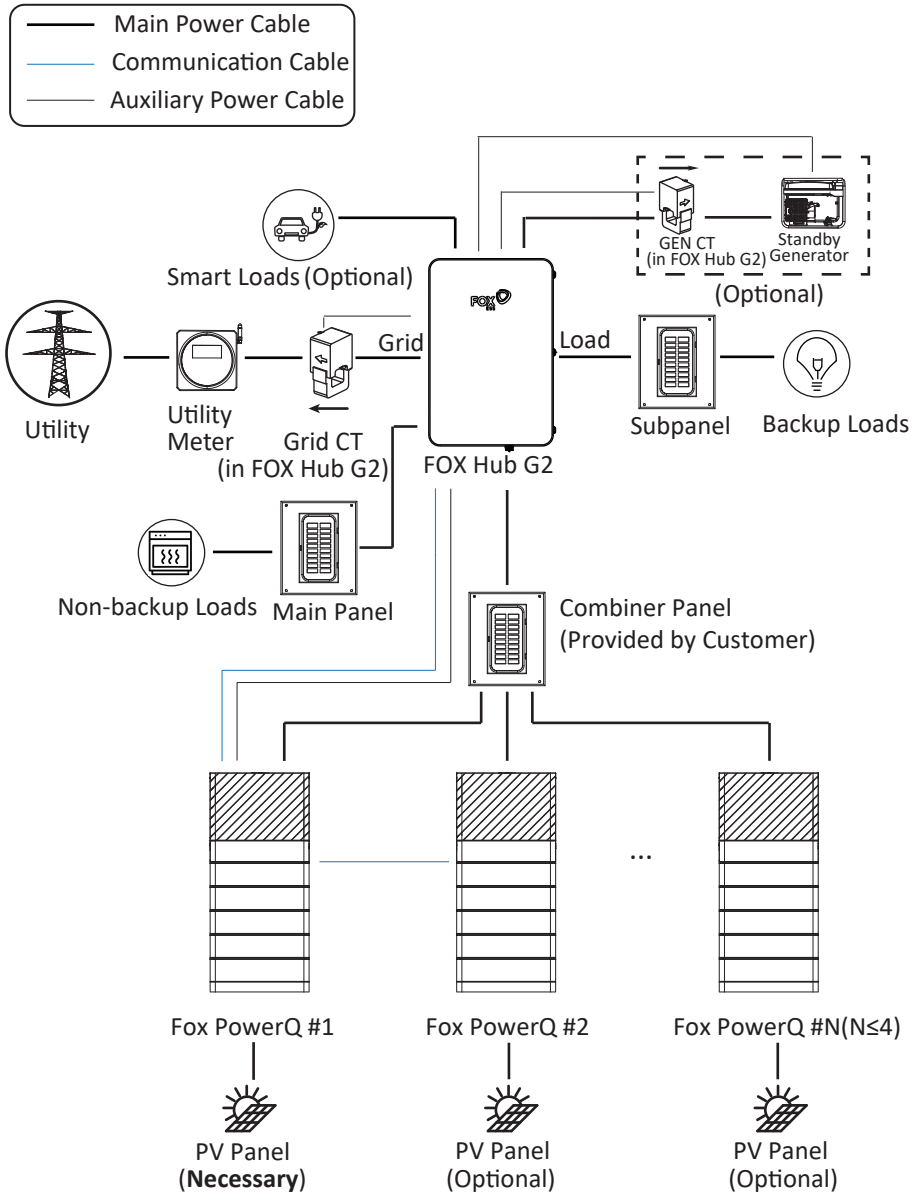

Partial-home Backup (DC Couple) (FOX Hub G2 not as Service Panel)

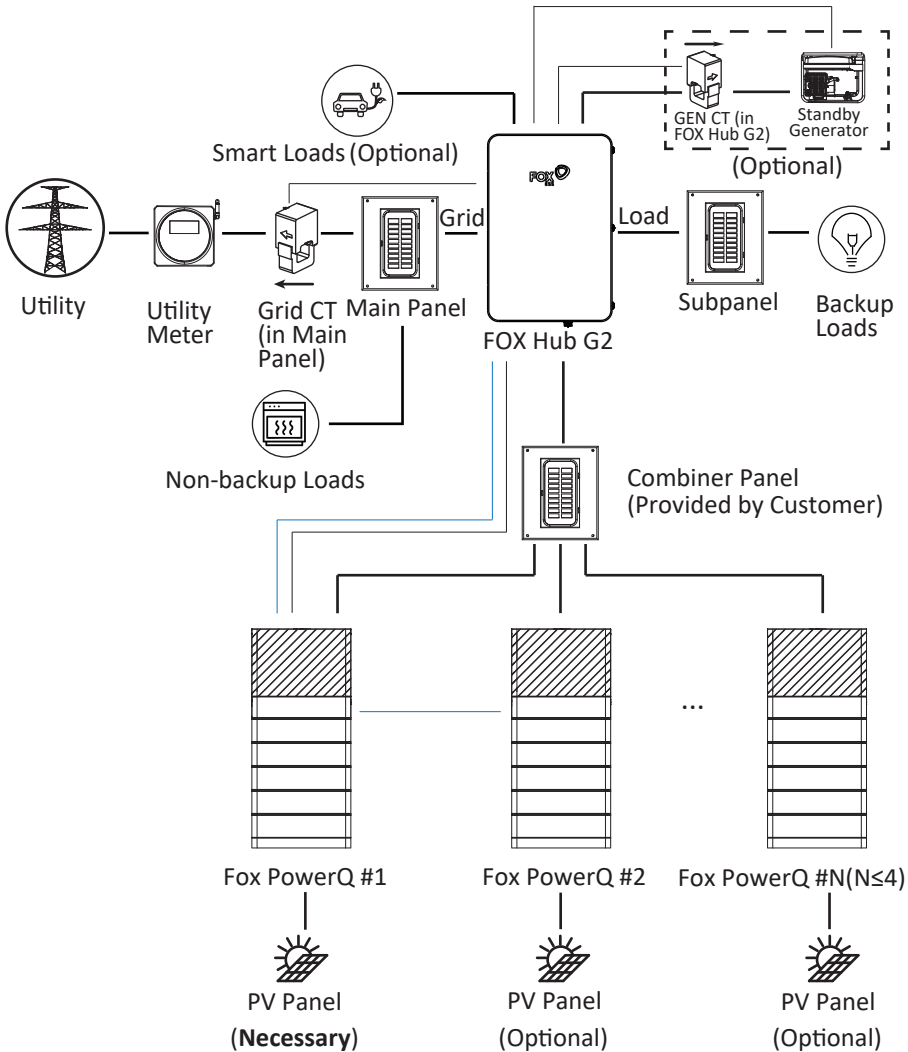
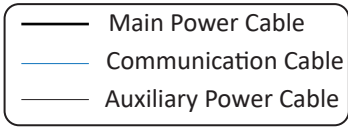

Partial-home Backup (AC Couple) (FOX Hub G2 as Service Panel)

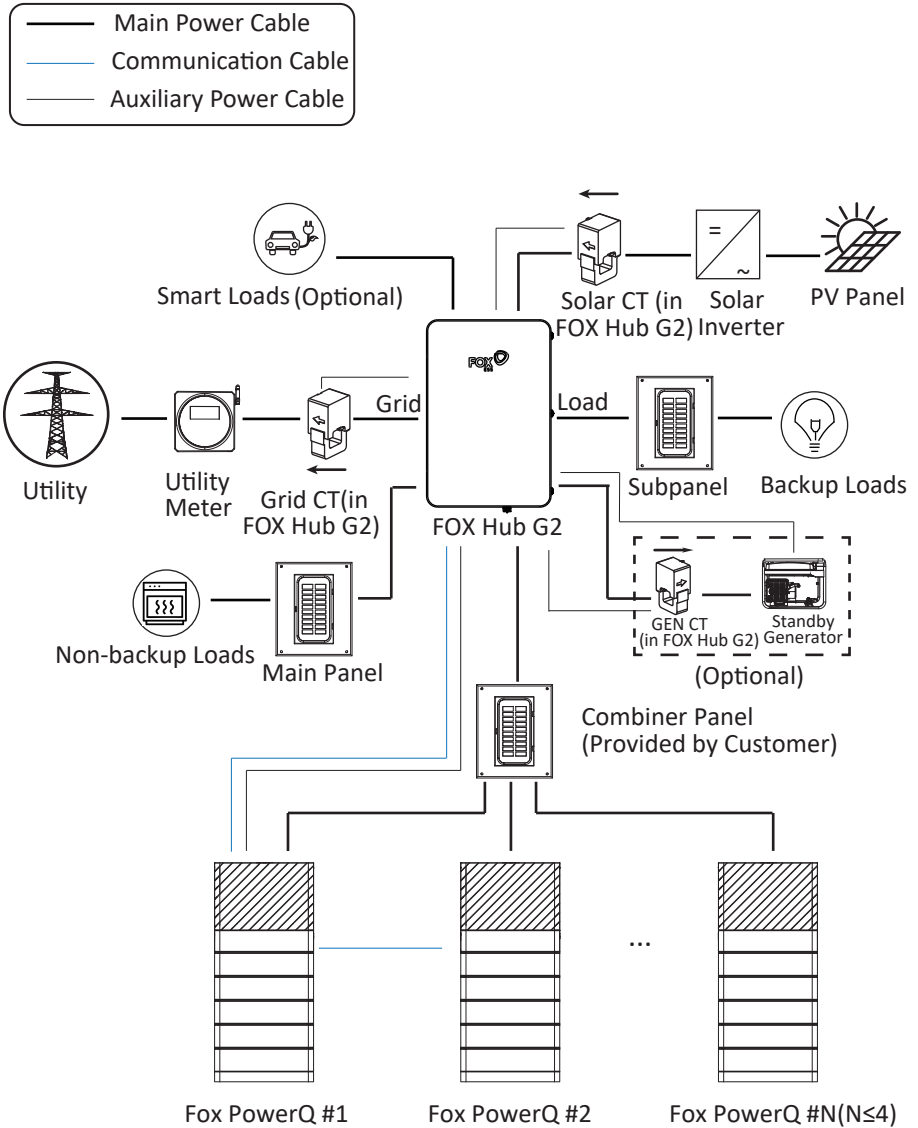

Partial-home Backup (AC Couple) (FOX Hub G2 not as Service Panel)

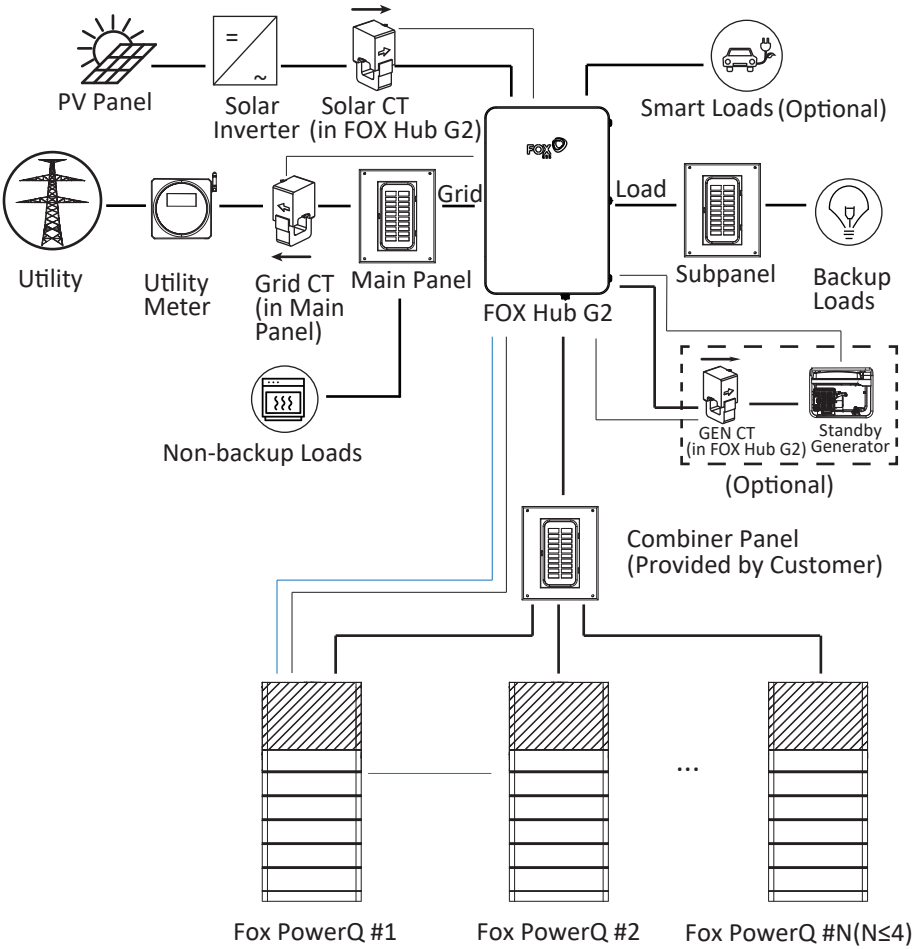
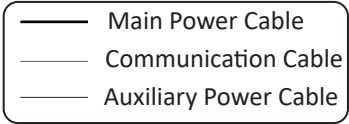

5 System Wiring Steps

5.1 FOX Hub G2 Overview

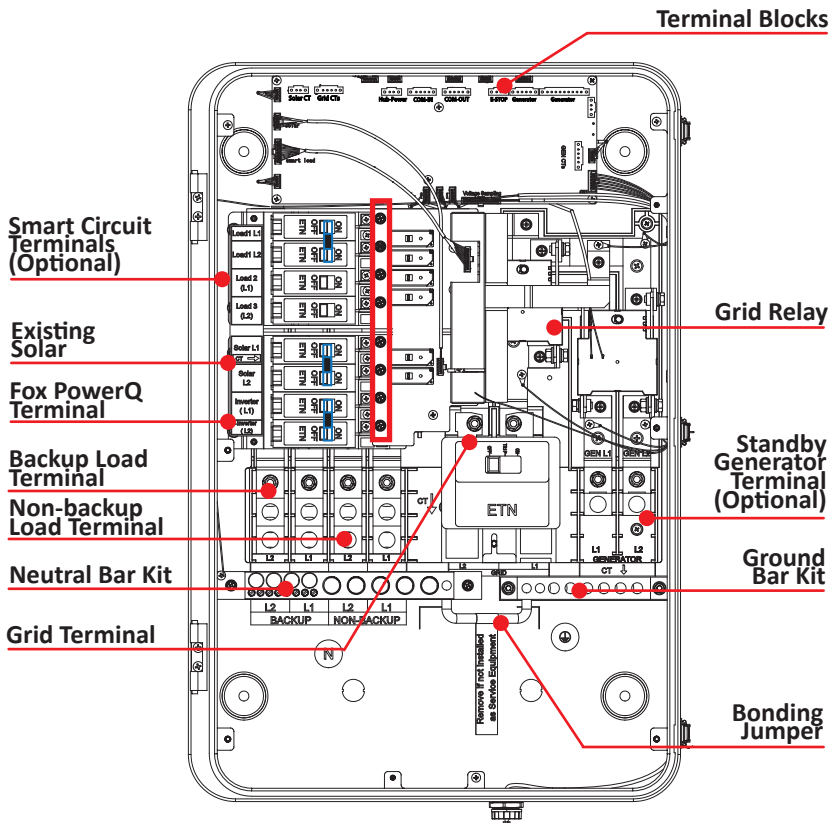

DANGER:

The framed screws are live. There is risk of electric shock. Disconnect units before servicing.

5.2 Is the FOX Hub G2 Installed as Service Panel?

- ① When the FOX Hub G2 is used as the service panel,
- a. main breaker and line side barriers (Eaton TICS300C) need to be installed;

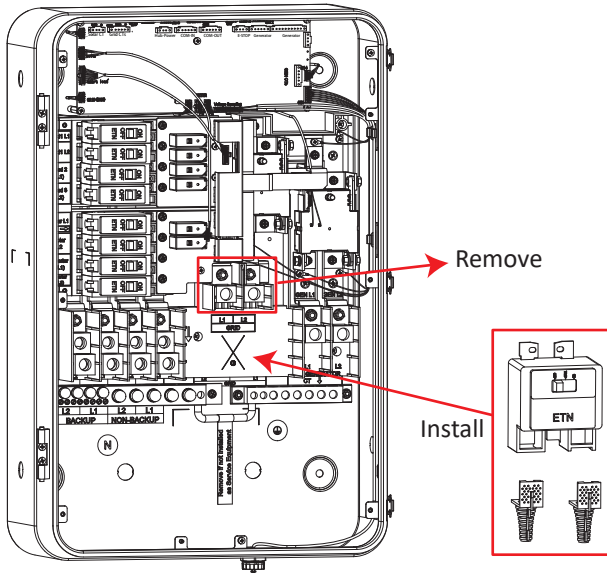

- b. labels of “SERVICE DISCONNECT” and “SUITABLE FOR USE AS SERVICE EQUIPMENT ONLY IN USA WHEN EQUIPPED WITH MAIN BREAKER” shall be applied to the black protection cover.

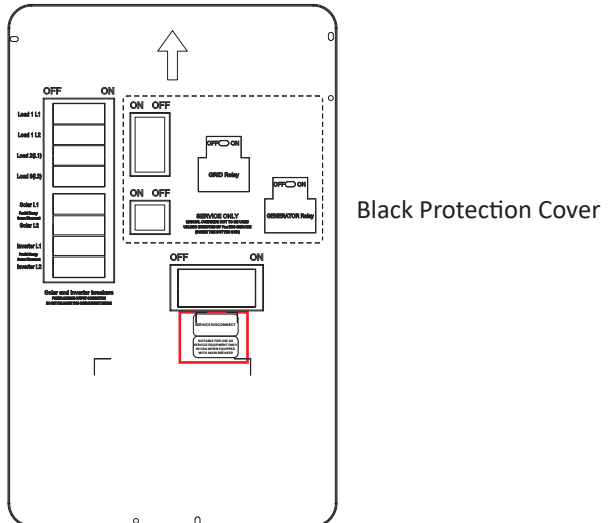

② When the FOX Hub G2 is not used as the service panel, bonding jumper needs to be removed.

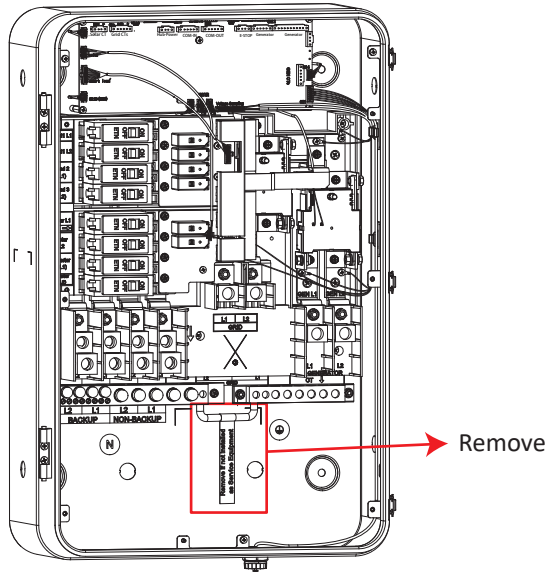

③ Recommended Breaker Models

Circuit	Compatitable Breaker
Smart Circuit (Back-fed breaker) (Optional)	CH230, CH235, CH240, CH245, CH250, CH260, CH270, CH280, CHF230, CHF235, CHF240, CHF245, CHF250, BR230, BR240, BR250, BR260, BR270, BR280, BR290, BRH230, BRH240, BRH250, BRH260, BRH270, BRH280, BRH290, BR170, BR160, BR150, BR140, BR130, BRH170, BRH160, BRH150, BRH140, BRH130
Existing Solar (Branch breaker)	CH230, CH235, CH240, CH245, CH250, CH260, CH270, CH280, CHF230, CHF235, CHF240, CHF245, CHF250, BR230, BR240, BR250, BR260, BR270, BR280, BR290, BRH230, BRH240, BRH250, BRH260, BRH270, BRH280, BRH290,
Fox PowerQ (Branch breaker)	CH230, CH235, CH240, CH245, CH250, CH260, CH270, CH280, CHF230, CHF235, CHF240, CHF245, CHF250, BR230, BR240, BR250, BR260, BR270, BR280, BR290, BRH230, BRH240, BRH250, BRH260, BRH270, BRH280, BRH290,
Grid (Main breaker) (Optional)	CSR2100, CSR2125N, CSR2150N, CSR2175N, CSR2200N, BW2100, BW2125, BW2150, BW2175, BW2200, BWH2100N, BWH2125N, BWH2150N, BWH2175N, BWH2200N

④ NEC 2023 Requirement of Current rating:

1.705.12 (b)(1): bus bar rating shall not less than main breaker rating + breaker of other power source (125% of power source output)

2.705.12 (b)(2): only two power sources: primary power source is located on opposite end of other power source. bus bar rating x 120% shall not less than main breaker rating + breaker of another power source (125% of power source output).
Need following marking:

POWER SOURCE OUTPUT CONNECTION. DO NOT RELOCATE THIS OVERCURRENT DEVICE

3.705.12 (b)(3): The sum of overcurrent protection device excluding main breaker shall not more than bus bar rating. And main breaker shall not more than bus bar rating. Need following marking:

WARNING:

THIS EQUIPMENT FED BY MULTIPLE SOURCES. TOTAL RATING OF ALL OVERCURRENT DEVICES EXCLUDING MAIN SUPPLY OVERCURRENT DEVICE SHALL NOT EXCEED AMPACITY OF BUSBAR.

5.3 FOX Hub G2 Power Cable Wiring

- The Fox PowerQ Connections to the FOX Hub G2 (One Fox PowerQ unit)

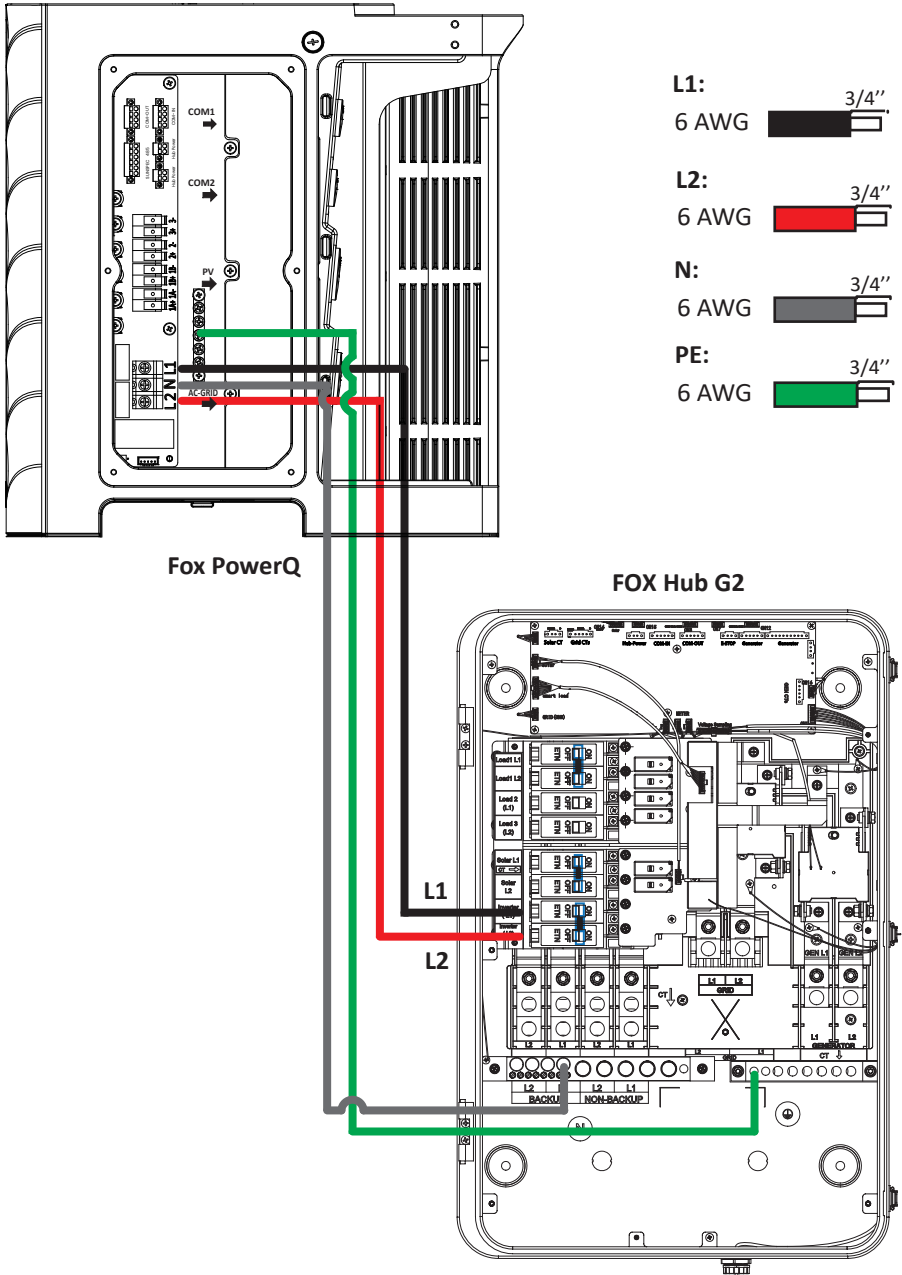

- The Fox PowerQ Connections to the FOX Hub G2 (2 to 4 Fox PowerQ units)

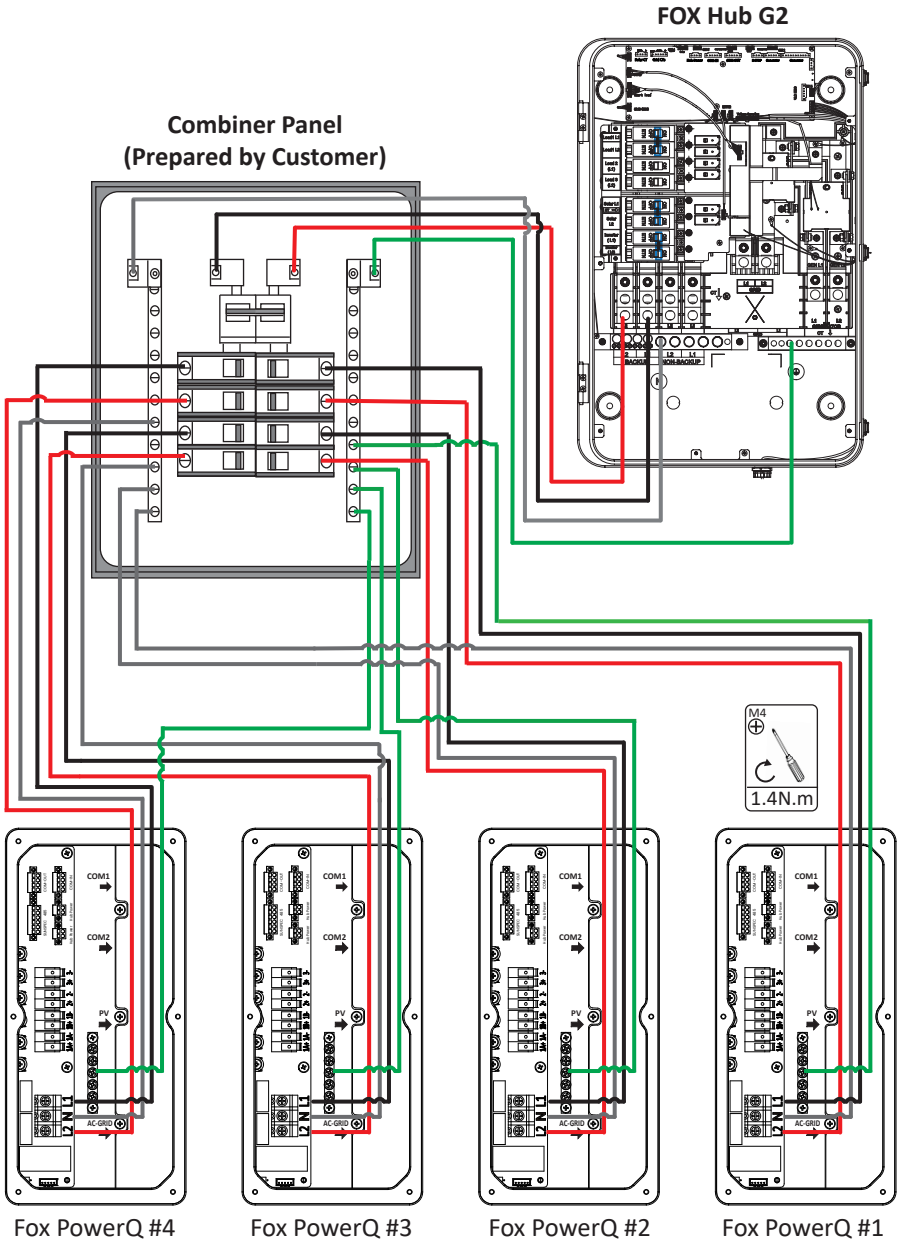

No. of Parellel Fox PowerQ units	Minimum Wire Gauge (Combiner Panel-FOX Hub G2)
2 Fox PowerQ units	2 AWG
3 Fox PowerQ units	2/0 AWG
4 Fox PowerQ units	4/0 AWG



No. of Parellel Fox PowerQ units	Wire Gauge (Combiner Panel— Fox PowerQ Unit)
2 Fox PowerQ units	6 AWG
3 Fox PowerQ units	6 AWG
4 Fox PowerQ units	6 AWG

• Backup Loads Connections to the FOX Hub G2

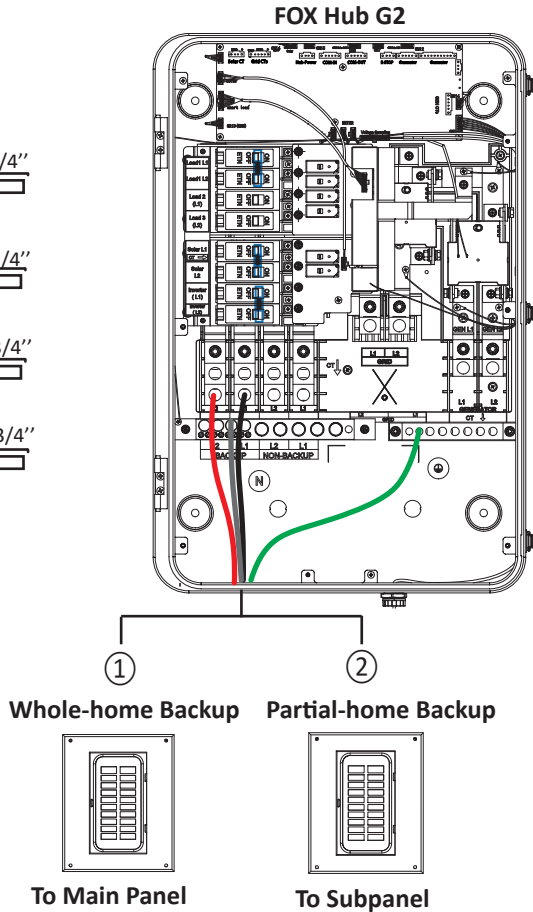
- L1:**
6 AWG - 250 kcmil  3/4"
- L2:**
6 AWG - 250 kcmil  3/4"
- N:**
6 AWG - 250 kcmil  3/4"
- PE:**
6 AWG - 2/0 AWG  3/4"



• Non-backup Loads Connections to the FOX Hub G2

- L1:**
6 AWG - 250 kcmil  3/4"
- L2:**
6 AWG - 250 kcmil  3/4"
- N:**
6 AWG - 250 kcmil  3/4"
- PE:**
6 AWG - 2/0 AWG  3/4"

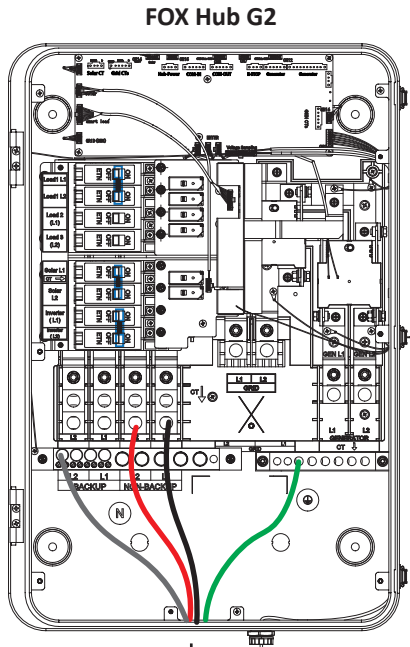

Partial-home Backup

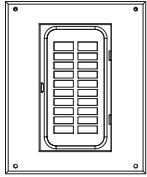

To Main Panel

• The Grid AC Power Connections to the FOX Hub G2

L1:
6 AWG - 4/0 AWG 

L2:
6 AWG - 4/0 AWG 

N:
6 AWG - 4/0 AWG 

L1:
6 AWG - 250 kcmil 

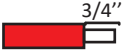
L2:
6 AWG - 250 kcmil 

N:
6 AWG - 250 kcmil 

PE:
6 AWG - 2/0 AWG 

FOX Hub G2

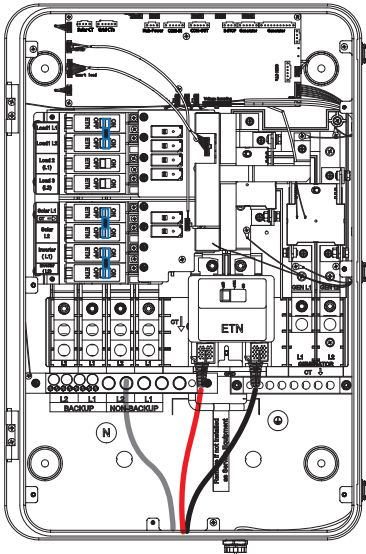

FOX Hub G2 as Service Panel

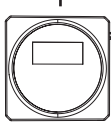

To Utility Meter

FOX Hub G2

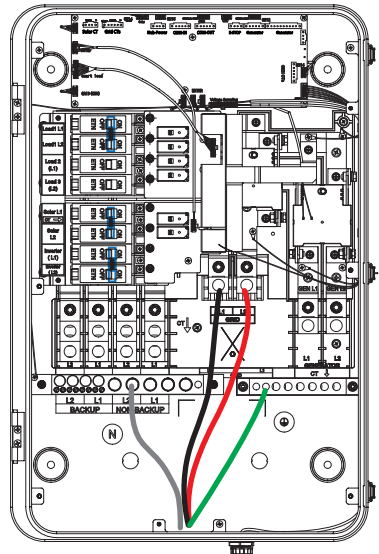



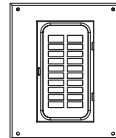

FOX Hub G2 not as Service Panel



To Main Panel

- The Existing Solar Inverter Connections to the FOX Hub G2 or Main Panel (Optional)

- L1:**
6 AWG - 1/0 AWG 
- L2:**
6 AWG - 1/0 AWG 
- N:**
6 AWG - 2/0 AWG 
- PE:**
6 AWG - 2/0 AWG 

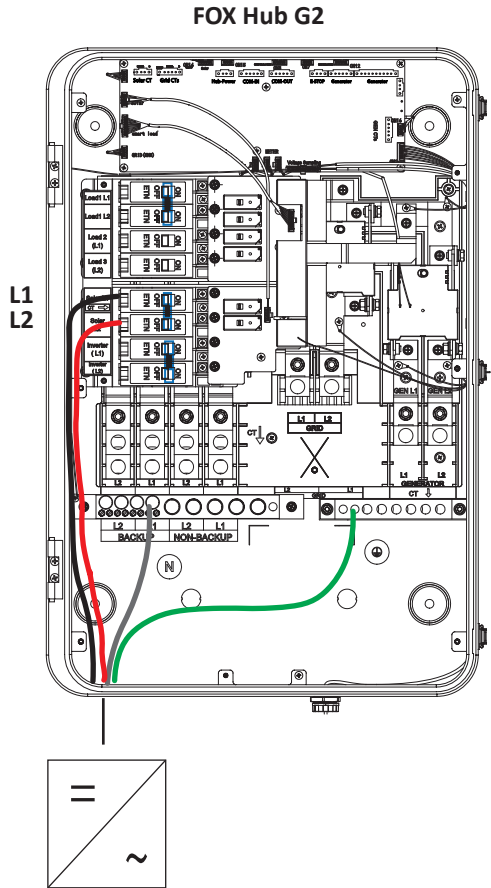

To Existing Solar Inverter

NOTE:



The conditions for connecting the existing solar inverter to the main panel are: the system has only one Fox PowerQ, no generator, and the power rating of the existing solar inverter is below the Fox PowerQ's power rating.

• The Smart Loads Connections to the FOX Hub G2 (Optional)

L1:
6 AWG - 1/0 AWG  3/4"

N:
6 AWG - 2/0 AWG  3/4"

L2:
6 AWG - 1/0 AWG  3/4"

PE:
6 AWG - 2/0 AWG  3/4"

FOX Hub G2

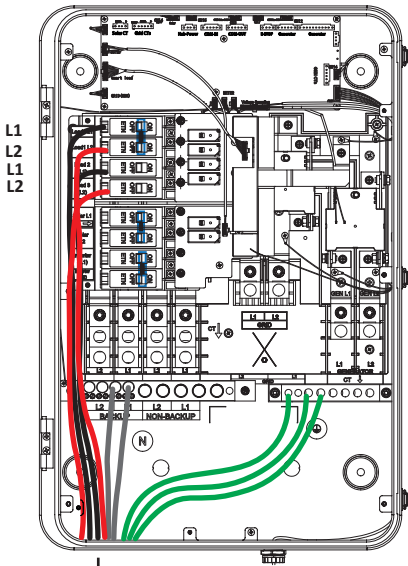

L1
L2
L1
L2



To 3 Smart Loads (240V, 120V, 120V)

FOX Hub G2

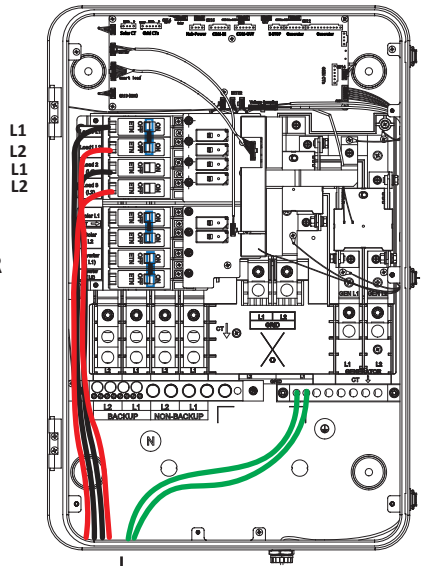



L1
L2
L1
L2

OR



To 2 Smart Loads (240V, 240V)

- The Standby Generator Connections to the FOX Hub G2 (Optional)

- L1:**
6 AWG - 250 kcmil  3/4"
- L2:**
6 AWG - 250 kcmil  3/4"
- N:**
6 AWG - 250 kcmil  3/4"
- PE:**
6 AWG - 2/0 AWG  3/4"

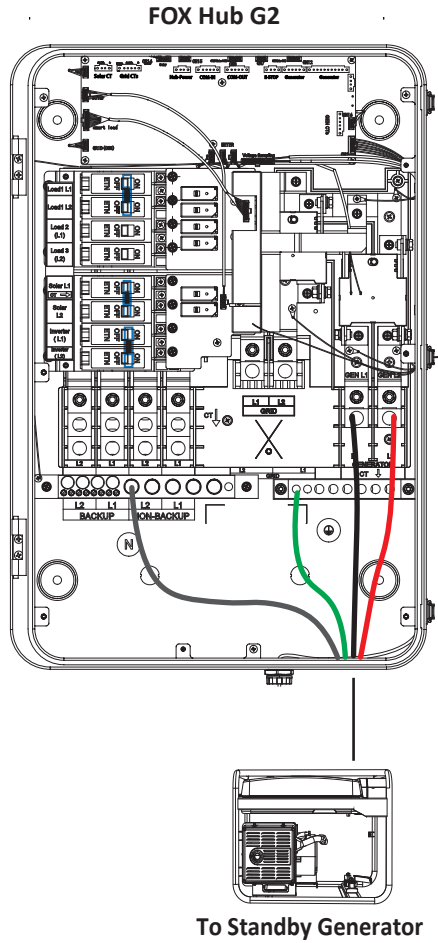

5.4 Fox PowerQ Power Cable Wiring

- The PV Panels Connections to the Fox PowerQ

Turn off the DC switch before connection.

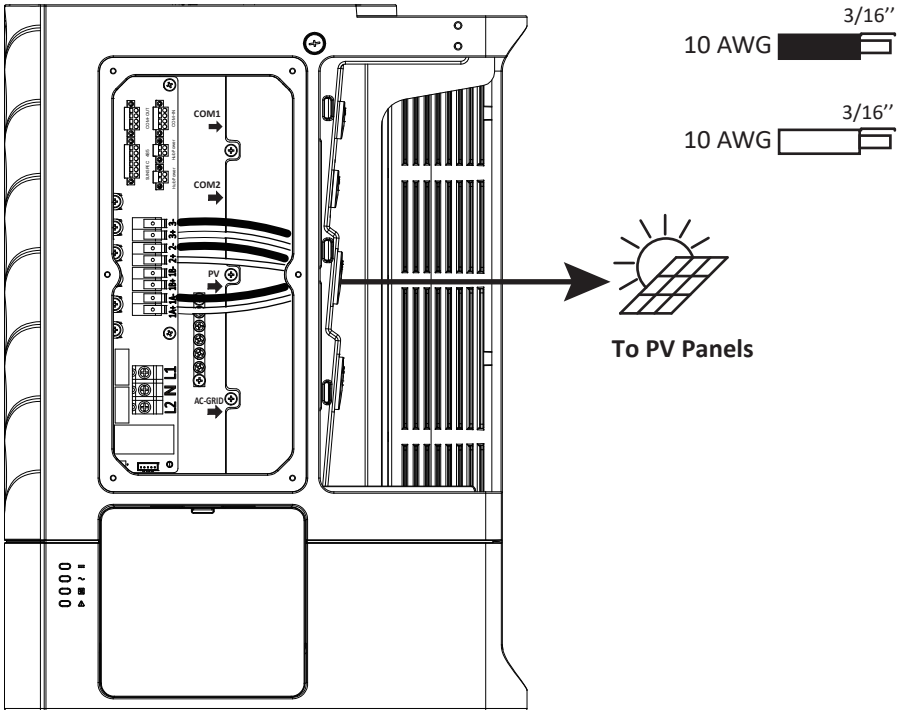

If there are ≤ 3 PV strings, 3 PV strings are preferentially connected to terminals 1A+, 1A-, 2+, 2-, 3+, 3-.

If there are 4 PV strings, the number of PV panels connected to terminals 1A+, 1A- needs to be the same as that connected to terminals 1B+, 1B-.

5.5 FOX Hub G2 Wiring (Communication & Auxiliary Power)

- The Fox PowerQ Connections to the FOX Hub G2 (1 to 4 Fox PowerQ Units)

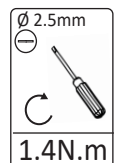

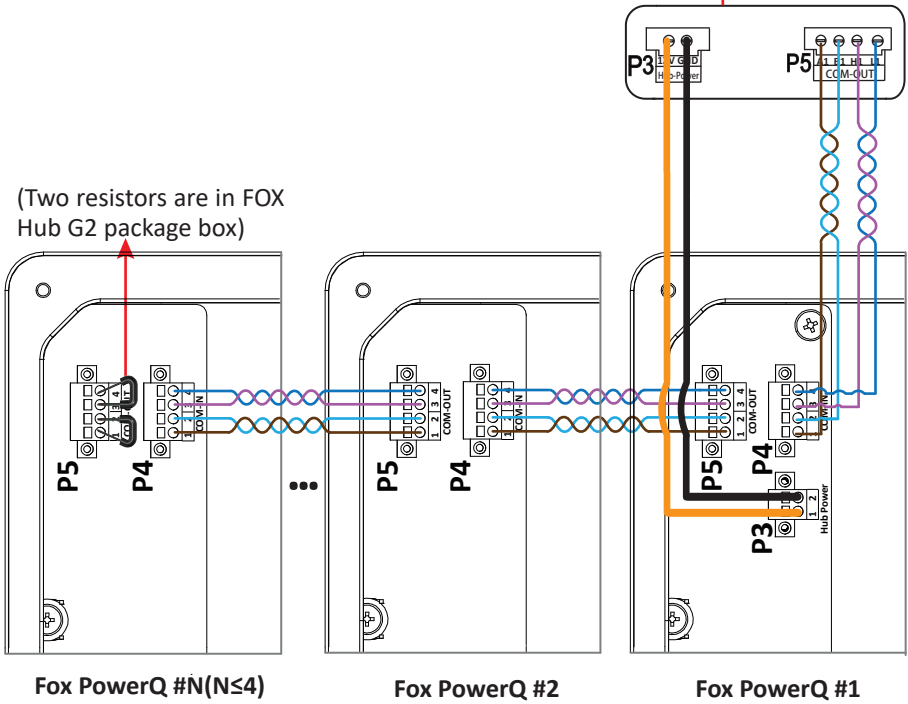
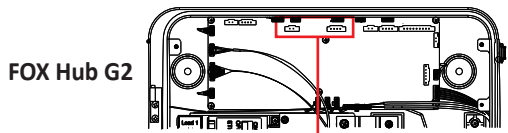

NOTE:

① In the last Fox PowerQ in the communication chain, plug the 4-pin P5 socket with two terminating 120Ω resistors.



② The twisted cables use shielded twisted pair with drain wire.

③ The maximum cable lengths between FOX Hub G2 and Fox PowerQ #1, and between Fox PowerQ units are 50m and 5m, respectively.

• The FOX Hub G2 Connections to the Standby Generator (Optional)

16 AWG 24-16 AWG

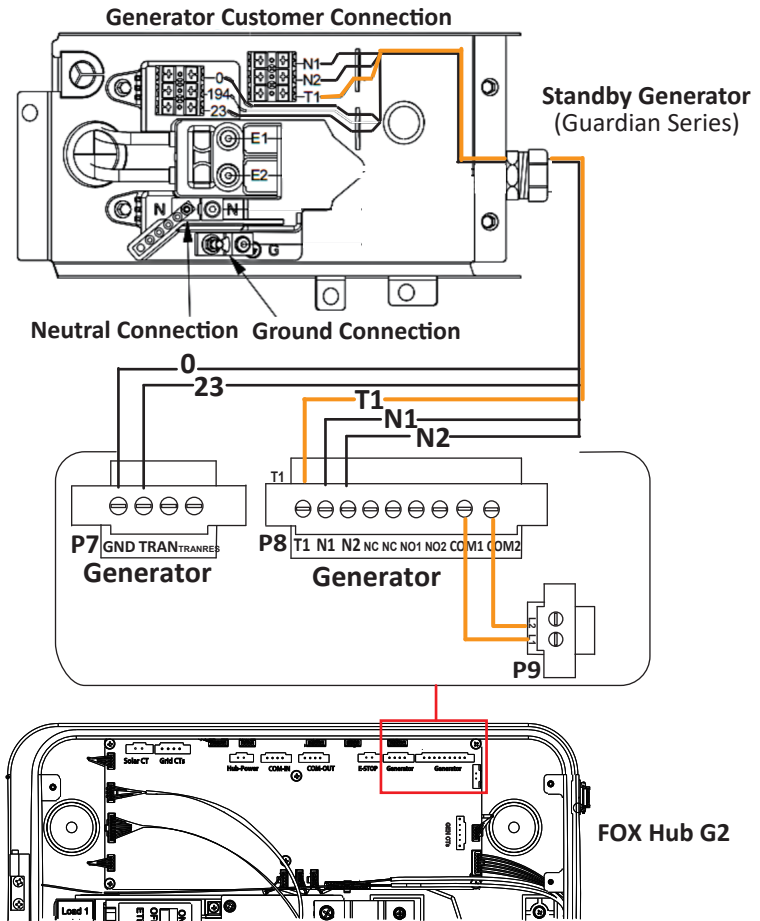

5.6 CT Wiring

- Solar CT Wiring between FOX Hub G2 and Solar Inverter (Optional)

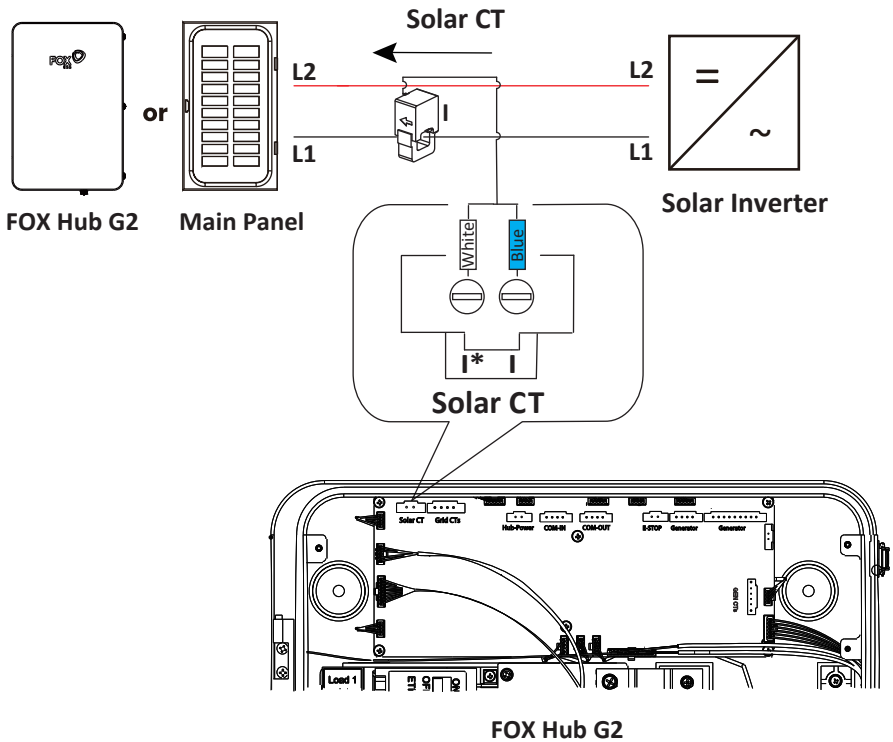

NOTE:



The condition for installing the solar CT in main panel is that the system has only one Fox PowerQ and no generator. Please refer to SLD for CT location.

• GEN CTs Wiring between Standby Generator and FOX Hub G2 (Optional)

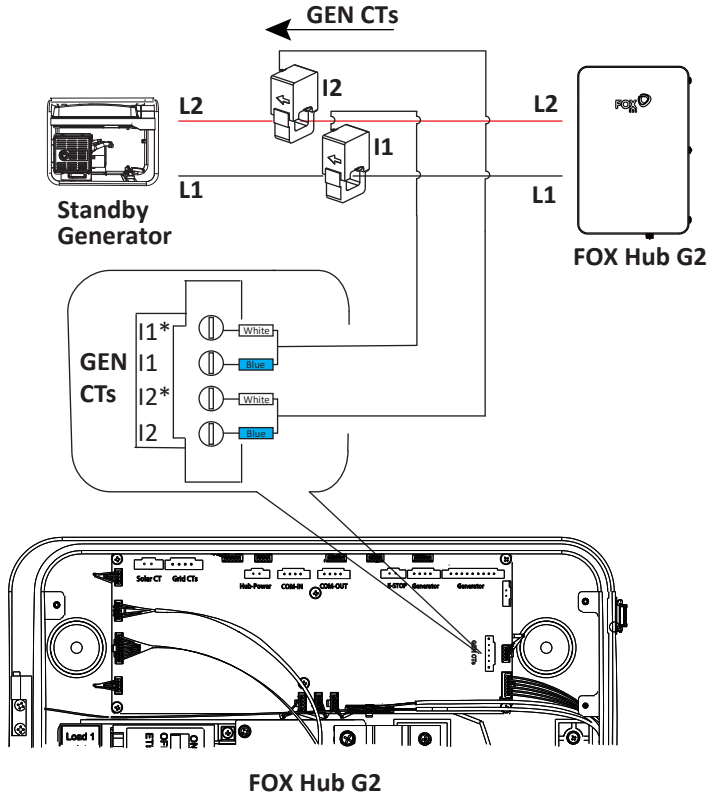

NOTE:



The GEN CTs are installed in FOX Hub G2. Please refer to SLD for CTs location.

• Grid CTs Wiring between Utility and FOX Hub G2

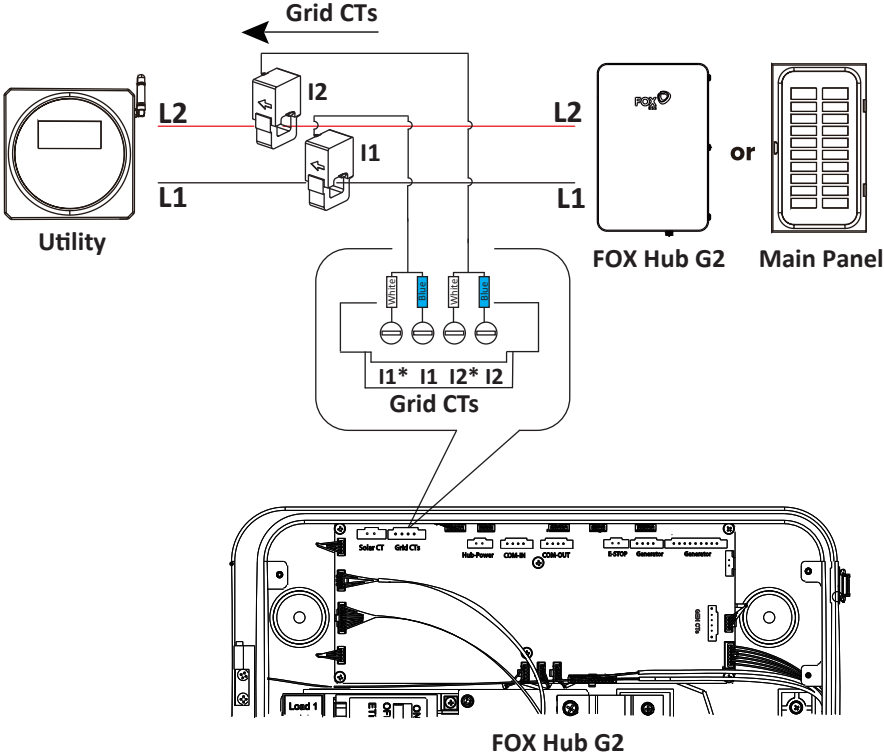

NOTE:



The condition for installing Grid CTs in main panel is partial home with FOX Hub G2 not as service panel. Please refer to SLD for CTs location.

5.7 E-STOP Wiring

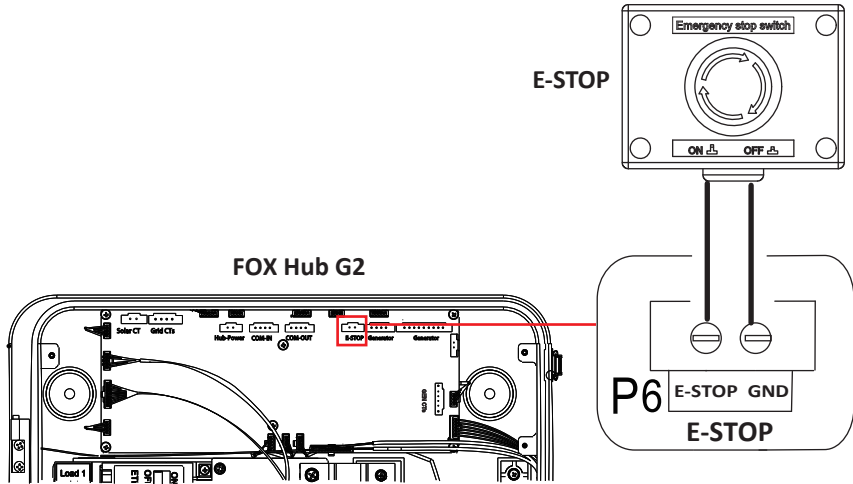

Step 1: remove the jumper on the P6 socket of the **FOX Hub G2**.

Step 2: connect the pins 1 and 2 of the P6 to the E-STOP.

5.8 Smart WiLAN & Smart 4GWiLAN Connection

- WiFi & 4G Installation: connect the Smart WiLAN to the **FOX Hub G2**.

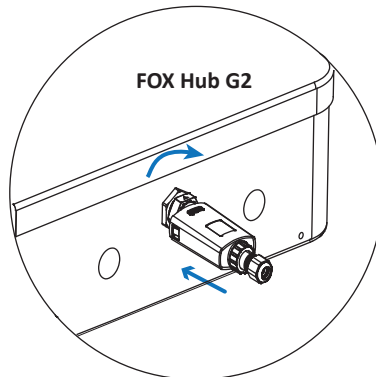

- LAN Installation: insert the network cable into the Smart WiLAN or the Smart 4GWiLAN, and connect it to the **FOX Hub G2**.

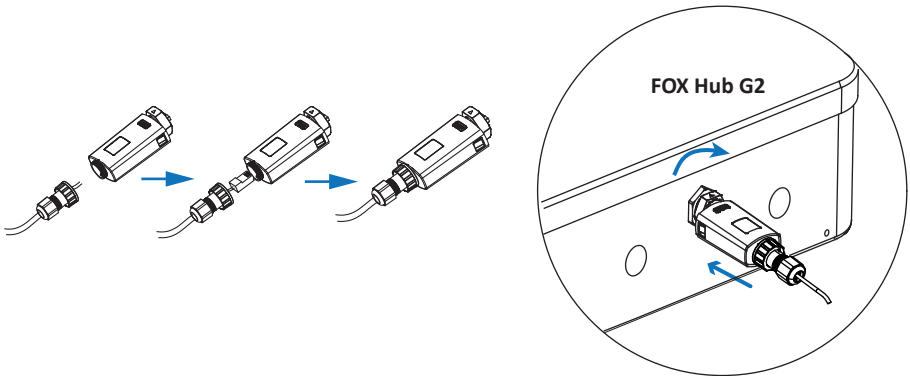

6 System Turn on

Please refer to the following steps to switch on the system.

1. Ensure all cables are connected properly.
2. Turn on the PV SWITCH on the Fox PowerQ (Only for New System), and AC breakers (in main panel or service panel).
3. Turn on BAT SWITCH first, then press “BAT POWER” button.
4. Check if green lights on the Fox PowerQ are solid on.

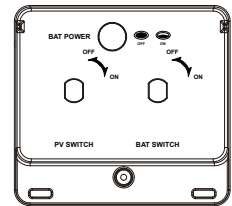
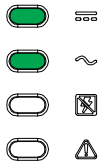

In case you need to turn off the system, please refer to the following steps:

1. Turn off the PV SWITCH, BAT SWITCH, and AC breakers.
2. Wait 5 minutes before you open the side cover of the Fox PowerQ (in case of repair).

7 Commissioning

Step 1: Search for FoxCloud US and download the app.



Or, scan the QR code to download the app.



After the app is installed, the FoxCloud US icon is displayed on the home screen.



Step 2:

• WiFi Configuration

① If using WiFi, tap , and tap “WiFi Configuration”.

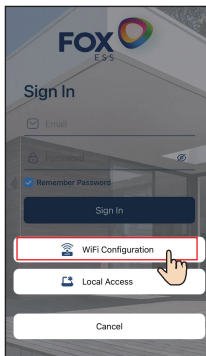
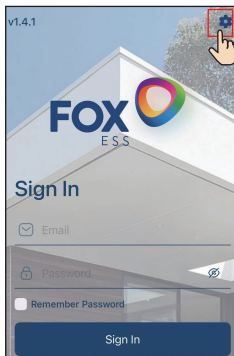

② Scan the QR code on the Smart WiLAN or the Smart 4GWiLAN, or enter the SN code, and then tap “confirm”. Input the house router WiFi’s information.

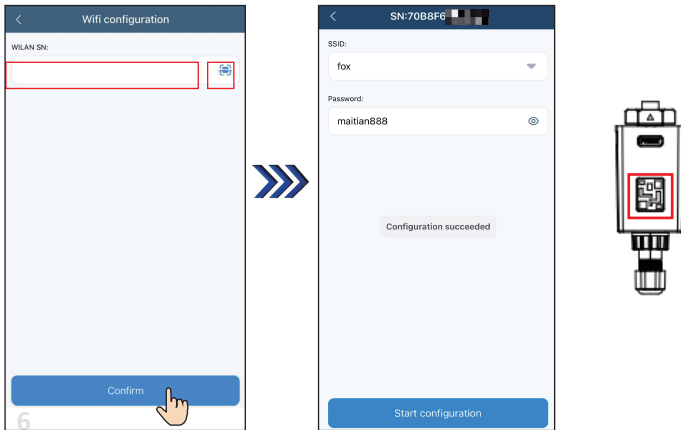

• 4G & LAN

If using 4G or LAN, there is no need for network configuration.

Light indication on the Smart WiLAN & Smart 4GWiLAN

Indicator	Status	Instructions
Red light	Blinking	Not connected to the server
	Solid on	Connected to the server
Green light	Blinking	Data transmission

Step 3: The installers sign up.

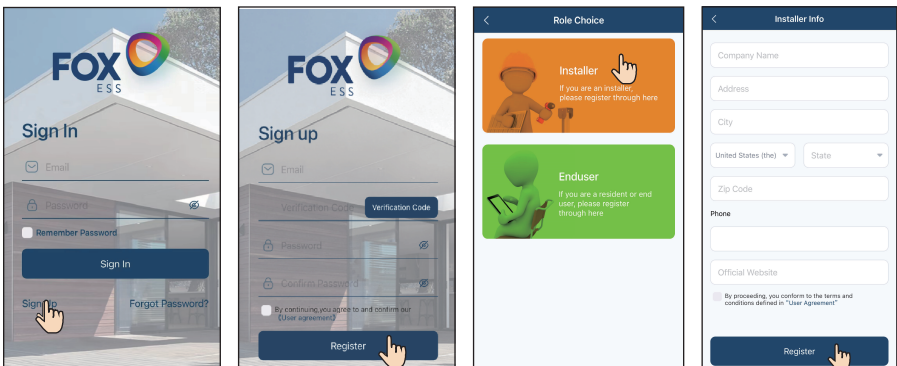

Step 4: The installers sign in to bind the end user's Fox PowerQ. Scan the QR code or manually enter the SN on the right side of the FOX Hub G2 or either Fox PowerQ.

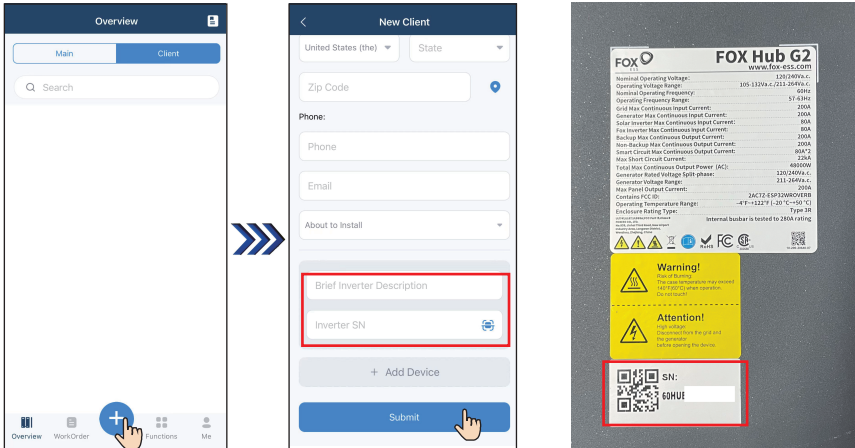

Step 5: Check system performance via the end user's account.

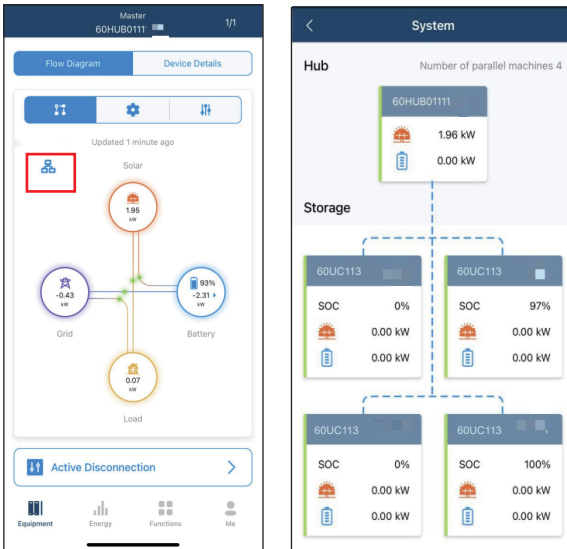

Step 6: Use the checklist below to make sure the necessary items are completed.

Item	Necessary or Optional	Status (✓ if completed)
1. Time Zone	Necessary	
2. Energy Mode	Necessary	
3. Parallel Fox PowerQ No.	Optional (Only needed when the number of Fox PowerQ units >1)	
4. Zero Back-feed	Optional	
5. Grid Code	Optional (Only needed when selling to countries except US; Change "USA" into your own country)	
6. Smart Load	Optional (Only needed when smart load is connected)	
7. Existing Solar Inverter Power	Optional (Only needed in Existing System)	
8. Charge from Grid	Optional (Only needed when main breaker cannot support inverter output during full load)	

Item 1: Set up the time zone via the end user's account.

Item 2: Configure the energy management mode via the end user's account.

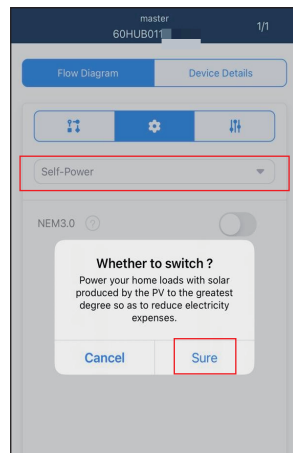
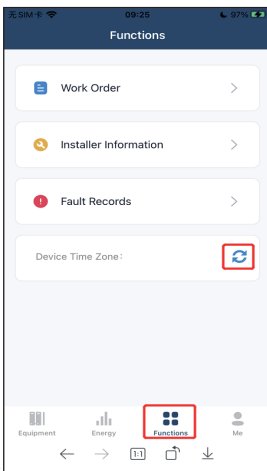

Item 3: Set the number of parallel Fox PowerQ units via the installer's account.

The first screenshot shows the 'Energy Status' page with a line graph of power flow. A red box highlights the 'Select Hub' button for HUB01.

The second screenshot shows the 'Device Details' page with a flow diagram. A red circle with the number '2' is next to the settings gear icon in the top right.

The third screenshot shows the 'Remote Setting' page. A red box highlights the 'ParallelParam' dropdown menu. Another red box highlights the 'NumberOfParallelMachines' input field, which has the value '4' and a 'Send' button. A red circle with the number '3' is next to the 'ParallelParam' dropdown, and a red circle with the number '4' is next to the 'AssignedAddressStatus' input field.

Item 4: Set the zero back-feed via the installer's account.

The first screenshot shows the 'Energy Status' page with a line graph of power flow. A red box highlights the 'Select Hub' button for HUB01.

The second screenshot shows the 'Device Details' page with a flow diagram. A red circle with the number '2' is next to the settings gear icon in the top right.

The third screenshot shows the 'Remote Setting' page. A red box highlights the 'ExportLimit' dropdown menu, the 'ExportLimit' section containing 'PowerLimitOfFeedGrid' (set to 'Enable') and 'PowerLimitPercentOfFeedGrid' (set to '0'). A red circle with the number '3' is next to the 'ExportLimit' dropdown.

Item 5: Set the grid code of **each Fox PowerQ** via the installer's account.

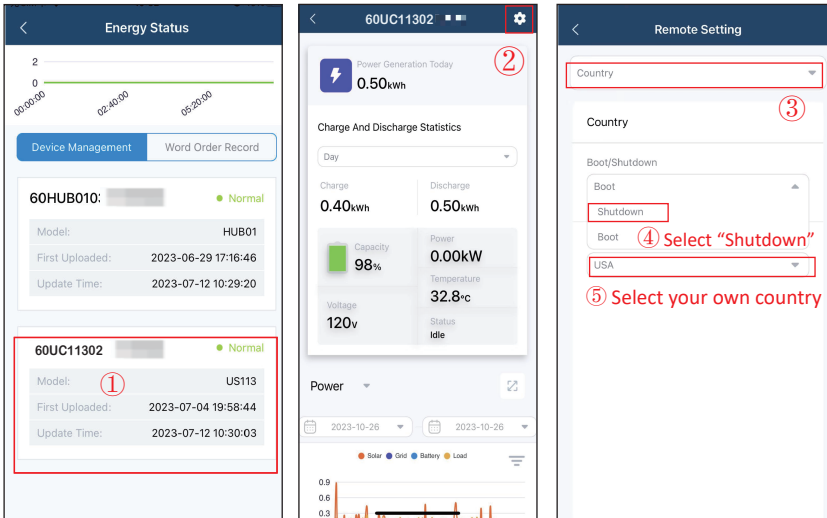

Item 6: Set the time plan of the power loads via the installer or end user's account.

• The installer's account

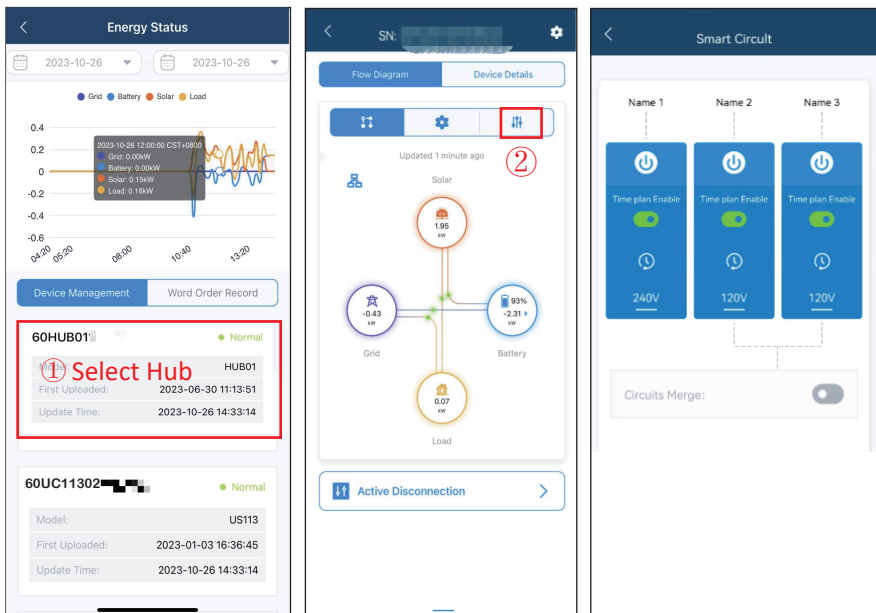

- The end user's account

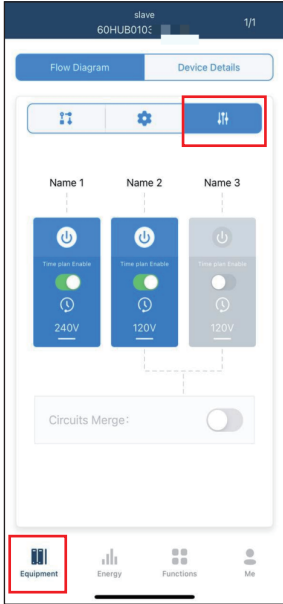

Item 7: Set the solar inverter power via the installer's account (Existing inverter only).

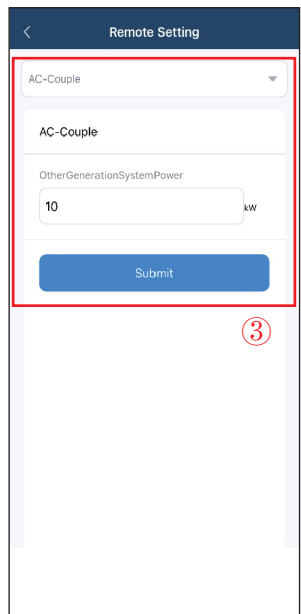
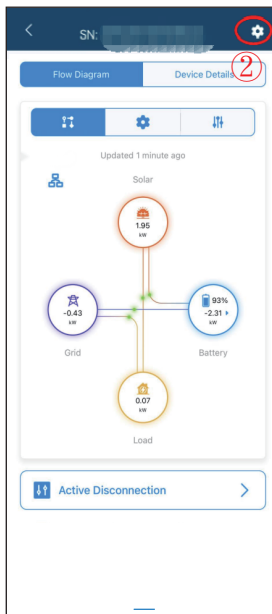
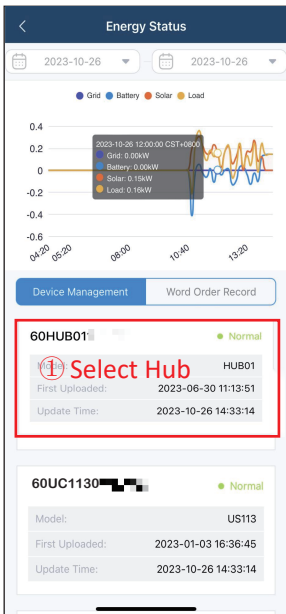

Item 8: Set the charge by grid value via the installer's account.

The image displays three screenshots from a mobile application interface, illustrating the steps to set the charge by grid value via the installer's account.

Screenshot 1 (Left): Energy Status
This screen shows a line graph of energy flow over time (2023-10-26). The legend indicates: Grid (blue), Battery (orange), Solar (green), and Load (red). Below the graph, the "Device Management" section lists two hubs:

- 60HUB01** (Normal): Select Hub (1), HUB01, First Uploaded: 2023-06-30 11:13:51, Update Time: 2023-10-26 14:33:14.
- 60UC1130** (Normal): Model: US113, First Uploaded: 2023-01-03 16:36:45, Update Time: 2023-10-26 14:33:14.

Screenshot 2 (Middle): Device Details
This screen shows the "Device Details" for a specific device (SN: [redacted]). It features a "Flow Diagram" and "Device Details" tabs. The flow diagram shows energy flow between Grid (-0.43 kW), Solar (1.95 kW), Battery (93% / -2.31 kW), and Load (0.07 kW). A gear icon in the top right corner is circled with a red "2".

Screenshot 3 (Right): Remote Setting
This screen shows the "Remote Setting" for the device. The "EMS" dropdown menu is circled with a red "3". The "ChargeByGridValue" is set to 11.40 kW. The "EMSMODE" dropdown menu is circled with a red "4".