

User Manual

US Series Energy Storage System

FOXESS CO., LTD.



Copyright © FOXESS CO., LTD. 2023. All rights reserved.

Without the prior written permission of FOXESS CO., LTD., this manual cannot be reproduced, distributed, or displayed in any form.

Notice

Please keep this manual where it will be accessible at all times. The information in this document is subject to change without notice. Every effort has been made in the preparation of this document to ensure accuracy of the contents, but all statements, information, and recommendations in this document do not constitute a warranty of any kind, express or implied.

This manual is intended for use by qualified electricians. The tasks described in this manual only can be performed by qualified electricians.

Please read this document carefully before installing or using the US Series Energy Storage System. Failure to follow any instructions or warnings in this document may result in damage to the equipment, personal electric shock, severe injury, or even death.

Table of Contents

1 Safety Statements.....	3
1.1 Appropriate Usage.....	3
1.2 Safety Symbols Used.....	3
1.3 PE Connection and Leakage Current.....	3
2 System Overview.....	9
2.1 System Components.....	9
2.1.1 US Series Hybrid Inverter.....	9
2.1.2 FOX Hub G2.....	18
2.1.3 ECS 4000 Battery.....	20
2.2 System Installation Requirement.....	23
2.2.1 System Installation Space.....	23
2.2.2 Installing FOX Hub G2 as Service Panel or not as Service Panel.....	23
2.3 Backup Options.....	25
2.4 Operating Mode.....	31
3 System Remote Operation and Monitoring.....	35
4 Service and Maintenance.....	36
4.1 Troubleshooting.....	36
4.2 Service and Maintenance.....	49
5 Decommissioning.....	51
5.1 Dismantling the US Series Energy Storage System.....	51
5.2 Packaging.....	51
5.3 Storage and Transportation.....	51
6 Appendix 1: Three-line Diagrams (1 FOX Hub G2+1 INV).....	52
7 Appendix 2: Three-line Diagrams (1 FOX Hub G2+Parallel INVs).....	60





1 Safety Statements

1.1 Appropriate Usage

The devices in the US series energy storage system are electrical devices. Please read this entire document to ensure the proper use of the US series energy storage system. Failure to follow this may void the warranty. Please strictly follow the safety instructions in this manual during operation, otherwise it may result in equipment malfunction, electrical shock, series injury or death.



1.2 Symbols Used

This section explains the symbols shown on the device and on the type label:

	<p>Danger!</p> <p>“Danger” indicates a hazardous situation which, if not avoided, will result in death or serious injury.</p>
	<p>Warning!</p> <p>“Warning” indicates a hazardous situation which, if not avoided, could result in death or serious injury.</p>
	<p>Caution!</p> <p>“Caution” indicates a hazardous situation which, if not avoided, could result in minor or moderate injury.</p>
	<p>Note!</p> <p>“Note” provides important tips and guidance.</p>

1.3 Appropriate Usage

The US series energy storage system is designed and tested in accordance with international safety requirements. However, certain safety precautions must be taken into account when installing and operating this system. The installer must read and follow all instructions, cautions, and warnings in this manual.



	<p>Warning!</p> <ul style="list-style-type: none"> • It is strictly prohibited to operate the product (including, but not limited to, handling, installation, electrical connection, powering up, maintenance, working at height, etc.) in bad weather, such as thunder, lightning, rain, snow, or winds of more than force six grades. • In case of fire, evacuate the building or product area and call the fire alarm. In any case, re-entry into the burning area is strictly prohibited.
	<p>Note!</p> <ul style="list-style-type: none"> • All operations including transport, installation, start-up, and maintenance, must be carried out by qualified, trained personnel. • The electrical installation & maintenance of the equipment shall be

	<p>conducted by a licensed electrician and shall comply with local wiring rules and regulations.</p> <ul style="list-style-type: none"> • Please operate the equipment under the condition that you are familiar with and understand the contents of this manual and have the appropriate tools.
--	---

1.3.1 Unpacking and Inspection



	<p>Note!</p> <ul style="list-style-type: none"> • Check all safety signs, warning labels and nameplates on the product. • Safety markings, warning labels and nameplates must be clearly visible and not be removed or covered before the product is scrapped. • Upon receipt of the product, check the appearance of the product and components for damage, check whether the product received is consistent with the actual product ordered, if there is a problem with the above check items, please do not install and contact Fox ESS.
---	---

1.3.2 Package Safety

	<p>Danger!</p> <ul style="list-style-type: none"> • Make sure the product is free of any electrical connections before installation. • When installing, if drilling is required, make sure you have avoided the pipeline and electric wire in the wall.
	<p>Warning!</p> <ul style="list-style-type: none"> • Before installation, check the unit to ensure it is free of any transport or handling damage, which could affect insulation integrity or safety clearances. Choose the installation location carefully and adhere to specified cooling requirements. Unauthorized removal of necessary protections, improper use, incorrect installation, and operation may lead to serious safety and shock hazards or equipment damage. • Any time the equipment has been disconnected from the public network, please be extremely cautious as some components can retain charge sufficient to create a shock hazard. Prior to touching any part of the equipment please ensure surfaces and equipment are under touch with safe temperatures and voltage potentials before proceeding.
	<p>Caution!</p> <ul style="list-style-type: none"> • If the product supports lifting and handling methods and needs to be lifted by heavy tools, it is prohibited for people to pass or stay underneath the product. • When handling the product, please consider the weight of the product and take care to maintain balance to prevent the product

	<p>from tipping or falling.</p>
	<p>Note!</p> <ul style="list-style-type: none"> • Before handling the product, always check to make sure that the tools you are using have been regularly maintained. • Before connecting the equipment to the power distribution grid, contact the local power distribution grid company to get appropriate approvals. This connection must be made only by qualified technical personnel. • Do not install the equipment in adverse environmental conditions such as in close proximity to flammable or explosive substances; in a corrosive environment; where there is exposure to extremely high or low temperatures; or where humidity is high. • Do not use the equipment when the safety devices do not work or are disabled. • Inform the manufacturer about non-standard installation conditions. • Use personal protective equipment, including gloves and eye protection during the installation.

1.3.3 Electrical Connection Safety

	<p>Danger!</p> <ul style="list-style-type: none"> • Before making electrical connections, make sure that the equipment is not damaged, otherwise it may be dangerous! • Always make sure that the equipment and all switches connected to it are disconnected before electrical connections are made, otherwise there is a risk of electric shock. • When making electrical connections, be sure to wear personal protective equipment and use special insulating tools. • Before touching a DC cable, always use a measuring device to ensure that the cable is not energized. • The equipment must not be connected to a PV string that requires positive or negative grounding.
	<p>Warning!</p> <ul style="list-style-type: none"> • Before supplying power, connect the ground wire. • Incorrect grounding can cause personal injury, death or equipment failure and increase electromagnetic interference. • Ensure that the size of the grounding wire meets the requirements of the safety regulations. • The cables used in the PV power system must be of suitable size, firmly connected and well insulated. • Before connecting the DC connector to the equipment, please check the positive and negative polarity of the PV string and insert the DC connector into the corresponding DC terminal. • During the installation and operation of the equipment, please make

	<p>sure that the positive or negative pole of the PV string will not be shorted to ground. Otherwise, it may cause AC and DC short circuit of the equipment, resulting in product damage, and loss caused is not covered by the warranty.</p>
--	---

1.3.4 Operation Safety

When routing cables, ensure a distance of at least 30 mm between the cables and heat-generating components or areas to protect the insulation layer of cables from aging and damage.



Danger!

- Do not touch the product enclosure.
- It is strictly forbidden to plug and unplug any connector on the equipment.
- Do not touch any wiring terminal of the equipment. Otherwise, electric shock may occur.
- Do not disassemble any parts of the equipment. Otherwise, electric shock may occur.
- It is strictly forbidden to touch any hot parts of the equipment (such as the heat sink). Otherwise, it may cause burns.
- Do not connect or remove any PV string or any PV module in a string. Otherwise, electric shock may occur.
- If the equipment is equipped with a DC switch, do not operate it. Otherwise, it may cause device damage or personal injury.

1.3.5 Maintenance Safety

Risk of equipment damage or personal injury due to incorrect service!



Danger!

- Before maintenance, disconnect the AC circuit breaker on the grid side and then the DC switch. If a fault that may cause personal injury or device damage is found before maintenance, disconnect the AC circuit breaker and wait until the night before operating the DC switch. Otherwise, a fire inside the product or an explosion may occur, causing personal injuries.
- After the equipment is powered off for 15 minutes, measure the voltage and current with professional instrument. Only when there is no voltage nor current can operators who wear protective equipment operate and maintain the equipment.
- Even if the equipment is shut down, it may still be hot and cause burns. Wear protective gloves before operating the equipment after it cools down.
- The power grid side may generate voltage. Always use a standard voltmeter to ensure that there is no voltage before touching.

**Note!**

- Do not use the equipment if any operating anomalies are found. Avoid temporary repairs.
- All repairs should be carried out using only approved spare parts, which must be installed in accordance with their intended use and by a licensed contractor or authorized Fox ESS service representative.
- If the paint on the equipment enclosure falls or rusts, repair it in time. Otherwise, the equipment performance may be affected.
- Do not use cleaning agents to clean the equipment. Otherwise, the equipment may be damaged, and the loss caused is not covered by the warranty.
- As the equipment contains no parts that can be maintained, never open the enclosure of the equipment or replace any internal components without authorization. Otherwise, the loss caused is not covered by the warranty.
- To avoid the risk of electric shock, do not perform any other maintenance operations beyond those described in this manual. If necessary, contact Fox ESS. Otherwise loss caused is not covered by the warranty.

1.3.6 Disposal Safety

Please scrap the product in accordance with relevant local regulations and standards to avoid property losses or casualties.

1.4 PE Connection and Leakage Current

PV System Residual Current Factors

- In every PV installation, several elements contribute to the current leakage to protective earth (PE). These elements can be divided into two main types.
- Capacitive discharge current-Discharge current is generated mainly by the parasitic capacitance of the PV modules to PE. The module type, the environmental conditions (rain, humidity) and even the distance of the modules from the roof can effect the discharge current. Other factors that may contribute to the parasitic capacitance are the inverter's internal capacitance to PE and external protection elements such as lightning protection.
- During operation, the DC bus is connected to the alternating current grid via the inverter. Thus, a portion of the alternating voltage amplitude arrives at the DC bus. The fluctuating voltage constantly changes the charge state of the parasitic PV capacitor (i.e. capacitance to PE). This is associated with a displacement current, which is proportional to the capacitance and the applied voltage amplitude.
- Residual current-if there is a fault, such as defective insulation, where an energized cable comes into contact with a grounded person, an additional current flows, known as a residual current.

Residual Current Device (RCD)

- The Fox ESS hybrid inverter incorporates a certified internal RCD (Residual Current Device) to protect against possible electrocution in case of a malfunction of the PV array, cables or inverter (DC). The RCD in the Fox ESS inverter can detect leakage on the DC side. There are 2 trip thresholds for the RCD as required by the UL1741 standard. A low threshold is used to protect against rapid changes in leakage typical of direct contact by people. A higher threshold is used for slowly rising leakage currents, to limit the current in grounding conductors for the safety. The default value for higher speed personal protection is 30 mA, and 30 mA, 60 mA, 150 mA per unit for lower speed fire safety.

2 System Overview

The US Series Energy Storage System is a whole home energy solution for residential users. The three key components are a hybrid inverter which can convert solar energy to AC energy and store energy into battery, FOX Hub G2 which is an energy management unit for whole-home power control, and an energy storage battery. Users can monitor and operate their storage system remotely via the FoxCloud US mobile phone app.

• System advantages:

- Easy installation: flexible configuration, plug and play set-up.
- High Voltage: Compatible with high-voltage batteries for maximum round-trip efficiency.
- Type 4X: engineered to last with maximum flexibility, and suitable for outdoor installation.
- Remote monitoring: monitor your system remotely via smartphone app or web portal.
- 100% imbalance for Split-Phase Loads.
- High backup power, up to 12.5 kW.
- High scalability, up to 4 inverters in parallel.
- Fast battery charging, up to 50 A charging and 60 A discharging current.
- RSD transmitter inside: a Tigo or APsystem transmitter is integrated in the inverter, and only RSD receivers should be installed by the installer.
- RGM inside: a 0.5% accuracy revenue grade meter (RGM) is integrated in the inverter and FOX Hub G2 to finance the solar array.
- UPS switchover time: the switchover time from on-grid to off-grid or from off-grid to on-grid is less than 20ms.
- Generator ready: the FOX Hub G2 is ready to connect to an up to 200 A generator.
- Smart loads: 240 V or 120 V loads can be connected to the FOX Hub G2 and controlled according to the time and SOC.
- Safety & Reliability: transformerless design with software and hardware protection.
- Arc detection function: capability of detecting up to 35 A arc current. When the PV panel produces arc, the inverter will shut down immediately, disconnect the grid-side relay, and turn off BDC relay and the battery. Meanwhile, turn off the quick shut-off device (RSD) to avoid the fire of the PV panel. After the arcing occurs, the inverter will report the arcing fault immediately and upload it to the cloud.

2.1 System Components

2.1.1 US Series Hybrid Inverter



The US series hybrid inverter is a high-quality hybrid inverter which can convert solar energy to AC energy and store energy into battery. The hybrid inverter can be used to optimize self-consumption, store in the battery for future use or feed-in to public grid. The US series hybrid inverter comprises the following models:

HI-3.8-US HI-5.7-US HI-7.6-US HI-9.6-US HI-11.4-US
 AC1-3.8-US AC1-5.7-US AC1-7.6-US AC1-9.6-US AC1-11.4-US

The appearance of the US series hybrid inverter is shown to the left.

Parameters of the US series hybrid inverter are described in the following table.

PV Input (For Hybrid Only)

Module	HI-3.8-US	HI-5.7-US	HI-7.6-US	HI-9.6-US	HI-11.4-US
PV INPUT					
Max. solar STC power	7600	11400	15200	19200	22800
Nominal DC voltage (V)	380				
Max. DC voltage (V)	600				
System startup voltage (V)	100				
MPPT voltage range (V)	80-550V				
MPPT voltage range (V) (Full load)	204-500	204-500	271-500	257-500	305-500
Max. PV input current per MPPT (A)	28/14			28/14/14	
Max. input short circuit current per MPPT (A)	44/22			44/22/22	
No. of MPPT	2			3	
Strings per MPPT	2/1			2/1/1	

AC Output/Input

Module	HI-3.8-US	HI-5.7-US	HI-7.6-US	HI-9.6-US	HI-11.4-US
OUTPUT AC (Grid Side)					
Nominal AC power (W)	3800	5700	7600	9600	11400
Max. AC apparent power (VA)	3800	5700	7600	9600	11400
Nominal AC output voltage (V)	240				
AC voltage range (V)	211-264				
Nominal AC output current (A)	15.8	23.8	31.7	40.0	47.5
Max.AC output current (A)	15.8	23.8	31.7	40.0	47.5
Nominal AC output frequency (Hz)	60				
Operating AC frequency range (Hz)	57~63				

Output power factor	>0.99 (0.8 leading - 0.8 lagging)				
Total harmonic distortion	<3%				
INPUT AC (Grid side)					
Max.AC input power (W)	3800	5700	7600	9600	11400
Input voltage range (V)	211-264				
Nominal AC input frequency (Hz)	60				
Max.AC input current (A)	15.8	23.8	31.7	40.0	47.5
OUTPUT AC (Backup)					
Rated output power (W)	3800	5700	7600	9600	11400
Rated output power @ different batteries (W)	3800 @H2 Battery	5700 @H2 Battery	5760 @H2 Battery	5760 @H2 Battery	5760 @H2 Battery
	3800 @H3 Battery	5700 @H3 Battery	7600 @H3 Battery	8640 @H3 Battery	8640 @H3 Battery
	3800 @H4 Battery	5700 @H4 Battery	7600 @H4 Battery	9600 @H4 Battery	11400 @H4 Battery
	3800 @H5 Battery	5700 @H5 Battery	7600 @H5 Battery	9600 @H5 Battery	11400 @H5 Battery
	3800 @H6 Battery	5700 @H6 Battery	7600 @H6 Battery	9600 @H6 Battery	11400 @H6 Battery
	3800 @H7 Battery	5700 @H7 Battery	7600 @H7 Battery	9600 @H7 Battery	11400 @H7 Battery
	3800 @H7 Battery	5700 @H7 Battery	7600 @H7 Battery	9600 @H7 Battery	11400 @H7 Battery
Max. apparent output power (VA)	4180	6270	8360	10560	12540
Peak output power for 60 sec. (W)	5130	7695	10260	12960	15390
Peak output power for 10 min. (W)	4560	6840	9120	11520	13680
Nominal AC output voltage	120V/240 V				
Max. continuous AC output current (A)	17.4	26.1	34.8	44.0	52.3
Nominal AC output frequency (Hz)	60				

Load start capacity (A) LRA	48 @H2 Battery	48 @H2 Battery	48 @H2 Battery	48 @H2 Battery	48 @H2 Battery
	72 @H3 Battery	72 @H3 Battery	72 @H3 Battery	72 @H3 Battery	72 @H3 Battery
	96 @H4 Battery	96 @H4 Battery	96 @H4 Battery	96 @H4 Battery	96 @H4 Battery
	110 @H5 Battery	110 @H5 Battery	110 @H5 Battery	110 @H5 Battery	110 @H5 Battery
	110 @H6 Battery	110 @H6 Battery	110 @H6 Battery	110 @H6 Battery	110 @H6 Battery
	110 @H7 Battery	110 @H7 Battery	110 @H7 Battery	110 @H7 Battery	110 @H7 Battery
	110 @H7 Battery	110 @H7 Battery	110 @H7 Battery	110 @H7 Battery	110 @H7 Battery
	110 @H7 Battery	110 @H7 Battery	110 @H7 Battery	110 @H7 Battery	110 @H7 Battery
Imbalance for split-phase loads	100%				
Maximum output overcurrent protection	25	35	45	60	70
Module	AC1-3.8-US	AC1-5.7-US	AC1-7.6-US	AC1-9.6-US	AC1-11.4-US
OUTPUT AC (Grid side)					
Nominal AC power (W)	3800	5700	7600	9600	11400
Max. AC apparent power (VA)	3800	5700	7600	9600	11400
Nominal AC output voltage (V)	240				
AC voltage range (V)	211-264				
Nominal AC output current (A)	15.8	23.8	31.7	40.0	47.5
Max.AC output current (A)	15.8	23.8	31.7	40.0	47.5
Nominal AC output frequency (Hz)	60				
Operating AC frequency range (Hz)	57-63				
Output power factor	>0.99 (0.8 leading - 0.8 lagging)				
Total harmonic distortion	<3%				
Maximum output overcurrent protection	20	30	40	50	60

INPUT AC (Grid side)					
Max.AC input power (W)	3800	5700	7600	9600	11400
Input voltage range (V)	211-264				
Nominal AC input frequency (Hz)	60				
Max.AC input current (A)	15.8	23.8	31.7	40.0	47.5
OUTPUT AC (Backup)					
Rated output power(W)	3800	5700	7600	9600	11400
Rated output power @ different batteries (W)	3800 @H2 Battery	5700 @H2 Battery	5760 @H2 Battery	5760 @H2 Battery	5760 @H2 Battery
	3800 @H3 Battery	5700 @H3 Battery	7600 @H3 Battery	8640 @H3 Battery	8640 @H3 Battery
	3800 @H4 Battery	5700 @H4 Battery	7600 @H4 Battery	9600 @H4 Battery	11400 @H4 Battery
	3800 @H5 Battery	5700 @H5 Battery	7600 @H5 Battery	9600 @H5 Battery	11400 @H5 Battery
	3800 @H6 Battery	5700 @H6 Battery	7600 @H6 Battery	9600 @H6 Battery	11400 @H6 Battery
	3800 @H7 Battery	5700 @H7 Battery	7600 @H7 Battery	9600 @H7 Battery	11400 @H7 Battery
	Max. apparent output power (VA)	4180	6270	8360	10560
Peak output power for 60 sec. (W)	5130	7695	10260	12960	15390
Peak output power for 10 min. (W)	4560	6840	9120	11520	13680
Nominal AC output voltage	120 V/240 V				
Max. continuous AC output current (A)	17.4	26.1	34.8	44.0	52.3
Nominal AC output frequency (Hz)	60				

Load Start Capacity (A) LRA	48 @H2 Battery	48 @H2 Battery	48 @H2 Battery	48 @H2 Battery	48 @H2 Battery	
	72 @H3 Battery	72 @H3 Battery	72 @H3 Battery	72 @H3 Battery	72 @H3 Battery	
	96 @H4 Battery	96 @H4 Battery	96 @H4 Battery	96 @H4 Battery	96 @H4 Battery	
	110 @H5 Battery	110 @H5 Battery	110 @H5 Battery	110 @H5 Battery	110 @H5 Battery	
	110 @H6 Battery	110 @H6 Battery	110 @H6 Battery	110 @H6 Battery	110 @H6 Battery	
	110 @H7 Battery	110 @H7 Battery	110 @H7 Battery	110 @H7 Battery	110 @H7 Battery	
	Imbalance for split-phase loads					100%

Battery

Module	H1-3.8-US	H1-5.7-US	H1-7.6-US	H1-9.6-US	H1-11.4-US
Battery					
Battery type	Li-ion				
Nominal battery voltage (V)	360				
DC operating voltage range (V)	85-460				
Full load DC operating voltage range (V)	95-460	140-460	190-460	235-460	280-460
Max. continuous charge and discharge current (A)	50				
Max. continuous charge/discharge power (W)	5700/4180	8550/6270	11400/8360	14400/10560	17100/12540
Peak discharge current for 60 sec. (A)	60				
BMS communication interface	CAN2.0				
Module	AC1-3.8-US	AC1-5.7-US	AC1-7.6-US	AC1-9.6-US	AC1-11.4-US
Battery					
Battery type	Li-ion				
Nominal battery voltage (V)	360				

DC operating voltage range (V)	85-460				
Full load DC operating voltage range (V)	95-460	140-460	190-460	235-460	280-460
Max. continuous charge and discharge current (A)	50				
Max. continuous charge/discharge power (W)	3800/4180	5700/6270	7600/8360	9600/10560	11400/12540
Peak discharge current for 60 sec. (A)	60				
BMS communication interface	CAN2.0				

Efficiency, Protection and Standard

Module	H1-3.8-US	H1-5.7-US	H1-7.6-US	H1-9.6-US	H1-11.4-US
EFFICIENCY					
Max. solar efficiency	97.4%	97.8%			
Max. efficiency (PV-BAT-AC)	91.8%	92.0%			
Round-trip efficiency	90.7%	90.9%			
CEC efficiency (BAT)	95.5%	96.5%	96.5%	97.0%	97.0%
CEC efficiency (PV)	96.0%	97.0%	97.0%	97.0%	97.5%
PROTECTION					
DC reverse-polarity protection	YES				
DC switch	YES				
DC surge protection	Type II				
Insulation resistance monitoring	YES				
AC surge protection	Type II				
AC short-circuit protection	YES				
Ground fault monitoring	YES				
Grid monitoring	YES				
Anti-islanding	YES				

protection					
Residual-current monitoring unit	YES				
AFCI protection	YES				
STANDARD					
Safety and EMC	UL1741 SA, UL 1741 SB, UL1741 CRD, CSA C22.2 No.107.1-16, UL1998, UL1699B, HECO SRD-V2.0; IEEE1547-2018, IEEE1547a-2020, IEEE1547.1-2020, Rule 21; FCC part15 CLASS B				
Module	AC1-3.8-US	AC1-5.7-US	AC1-7.6-US	AC1-9.6-US	AC1-11.4-US
EFFICIENCY					
Max. efficiency	97.60%				
Round-trip efficiency	90.90%				
CEC efficiency (PV)	95.5%	96.5%	96.5%	97.0%	97.0%
PROTECTION					
DC surge protection	Type II				
Insulation resistance monitoring	YES				
AC surge protection	Type II				
AC short-circuit protection	YES				
Ground fault monitoring	YES				
Grid monitoring	YES				
Anti-islanding protection	YES				
Residual-current monitoring unit	YES				
STANDARD					
Safety and EMC	UL1741 SA, UL 1741 SB, UL1741 CRD, CSA C22.2 No.107.1-16, UL1998, UL1699B, HECO SRD-V2.0; IEEE1547-2018, IEEE1547a-2020, IEEE1547.1-2020, Rule 21; FCC part15 CLASS B				

General Data

Module	H1-3.8-US	H1-5.7-US	H1-7.6-US	H1-9.6-US	H1-11.4-US
Dimension and Weight					
Dimension (W*H*D)	18.2 inch*25.9 inch*9.2 inch (462 mm*658 mm*234.5 mm)				
Weight	83.8 lbs/38 kg				
Enclosure rating	Type 4X				
Operation temperature range	-13 °F~+140 °F (-25 °C ~ +60 °C) derating above 104 °F(40 °C)				
Relative humidity	0-100% (No Condensation)				

Typical noise emission	<35 dB				
Max. operation altitude	9,843 ft(3,000 m) (>6, 560 ft (2000 m) derating)				
Internal consumption at night	<25 W				
Topology	Transformerless				
Cooling method	Natural convection				
Maximum number of inverters (Parallel)	4				
HMI					
Display	LED, App, Website				
Communication interface	CAN2.0, RS485, Meter, CT, ISO alarm, SUNSPEC				
Monitoring Module: Smart WiLAN/GPRS	Optional				
Warranty	Standard 12.5 years				
Module	AC1-3.8-US	AC1-5.7-US	AC1-7.6-US	AC1-9.6-US	AC1-11.4-US
Dimension and Weight					
Dimension (W*H*D)	18.2 inch*25.9 inch*9.2 inch (462 mm*658 mm*234.5 mm)				
Weight	80.5 lbs/36.5 kg				
Enclosure rating	Type 4X				
Operation temperature range	-13 °F~+140 °F (-25 °C ~ +60 °C) derating above 104 °F (40 °C)				
Relative humidity	0-100% (No Condensation)				
Typical noise emission	<35 dB				
Max. operation altitude	9,843 ft (3,000 m) (>6,560 ft (2,000 m) derating)				
Internal Consumption at Night	<25 W				
Topology	Transformerless				
Cooling Method	Natural convection				
Maximum number of inverters (Parallel)	4				
HMI					
Display	LED, App, Website				

Communication interface	CAN2.0, RS485, Meter, CT, ISO alarm, SUNSPEC
Monitoring Module: Smart WiLAN/GPRS	Optional
Warranty	Standard 12.5 years

2.1.2 FOX Hub G2



FOX Hub G2 is an energy management unit with a smart circuits module, a backup loads module, a non-backup loads module, a generator assembly module and a communications module.

The appearance of the FOX Hub G2 is shown to the left.

Parameters of the FOX Hub G2 are described in the following table.

MODULE	FOX Hub G2
INPUT FROM GRID	
AC current input	200 A
Rated AC voltage	240 Vac
Rated AC power	48000 W
AC voltage range	211-264 Vac
AC frequency (nominal)	60 Hz
AC frequency range	57-63 Hz
Micro-grid interconnection device rated current	200 A
Short-circuit breaking capacity	22 KA
Grid disconnection switchover time	<20 ms
OUTPUT TO MAIN DISTRIBUTION PANEL	
Maximum AC current output	200 A
AC L-L output voltage (nominal)	240 Vac
AC L-L output voltage range	211-264 Vac
AC frequency (nominal)	60 Hz
AC frequency range	57-63 Hz
AC L-N output voltage in backup (nominal)	120 V
AC L-N output voltage range in backup	105-132 V
AC frequency range in backup	55-65 Hz
Maximum number of inverters	4 #
Rated AC power	48000 W
GENERATOR (OPTIONAL)	
Maximum rated AC power	48000 W

AC voltage range	211-264 Vac
Maximum continuous input current	200 Adc
Dry contact switch voltage rating	250/30 Vac/Vdc
Dry contact switch current rating	0.5 A (250 Vac)/3 A(30 Vdc)
2-wire start switch	Yes
TERMINAL (OPTIONAL)	
Solar terminal	80 A
Fox ESS inverter terminal	80 A
Smart circuits 1, 2	80 A
Smart circuit 3	80 A
Non-backup load terminal	200 A
Backup load terminal	200 A
ADDITIONAL FEATURES	
Communication	CAN, RS485
Energy meter (for Import/Export)	0.5% Accuracy
STANDARD COMPLIANCE	
Safety	UL67,UL869A,UL916,UL1741,CSA22.2 NO.107
Emissions	FCC Part 15 Class B
INSTALLATION SPECIFICATIONS	
Supported inverters	FOX US Series
AC from grid conduit size/AWG range	2.5"Conduits/6 AWG-250 kcmil
AC generator input conduit size/AWG range	2.5"Conduits/6 AWG-250 kcmil
Communication conduit size/AWG range	1"Conduits/24 AWG-16 AWG
Weight	37.4 lbs/17 Kg
Cooling	Natural Convection
Noise	<35dB
Operating temperature range	-4 °F~+122 °F (-20 °C ~ +50 °C)
Protection rating	Type 3R
Dimensions (H*W*D)	26.2 in*17.4 in*6.2 in/ 665 mm*443 mm*156.6 mm
Warranty	Standard 12.5 years



Note!

The FOX Hub G2 may not come with the capability to connect to smart circuit and generator. Please refer to the checkmarks on the shipping mark of the FOX Hub G2. If "smart circuit" or "generator" is checked, the FOX Hub G2 comes with the corresponding functions.

FOX Hub

MODEL: FOX Hub G2

Date: 22W01	G.W: 23kg(51lb)	N.W: 18kg(40lb)
Dimension(mm): 780(W)*540(H)*276(D)		
Factory Certification: ISO9001:2015 Safety/EMC Certification 		
<input type="checkbox"/> WILAN	<input type="checkbox"/> 4GWILAN	<input type="checkbox"/> GENERATOR
<input type="checkbox"/> SMART CIRCUIT		

P/N: **30-403-00002-00**

S/N: 
60AT2530211A002



Shipping mark

MADE IN CHINA

2.1.3 ECS 4000 Battery



The ECS 4000 battery is a stackable modularized battery which stacks up to 7 modules in US. The battery is capable of storing excess energy generated during times of low demand and supplying it during times of high demand. The battery is flexible for both whole home and partial home backup.







The appearance of the ECS 4000 battery is shown to the left.

Parameters of the ECS 4000 battery are described in the following table.

Specifications for CS	
Model NO.	CS4000
Max. charge/discharge current	50 A
Operating temperature	-10 °C~ 55 °C
Storage temperature	-20 °C~ 55 °C
Humidity	5 %~95 %
Normal voltage	57.6 V
Normal capacity	69 Ah
Normal energy	3.97 kWh
Battery voltage range	48.6~65.7 V
Max. Continuous discharge/charge current	50/50 A
(CC-CV) Standard charging current	35 A
Constant current and voltage charging cut-off current	3.5 A
Peak discharge current (60s)	65 A
Dimensions (L*W*H)	570 mm*380 mm*155 mm
Weight	35 Kg±1 Kg

Communication interfaces	CAN
--------------------------	-----

Specifications for CM	
Model NO.	CM4000
Max. charge/discharge current	50 A
Operating temperature	-10 °C~ 55 °C
Storage temperature	-20 °C~ 55 °C
Humidity	5 %~95 %
Normal voltage	57.6 V
Normal capacity	69 Ah
Normal energy	3.97 kWh
Battery voltage range	48.6 V~65.7 V
Max. continuous discharge/charge current	50 A/50 A
(CC-CV) Standard charging current	35 A
Constant current and voltage charging cut-off current	3.5 A
Peak discharge current (60s)	65 A
Dimensions (L*W*H)	570 mm*380 mm*170 mm
Weight	39 Kg±1 Kg

Specifications for ECS4000						
Model No.	ECS4000-H2	ECS4000-H3	ECS4000-H4	ECS4000-H5	ECS4000-H6	ECS4000-H7
Technical Properties						
Battery designation	IFpP42/151/1 08/[(18S)2S] E/-10+50/90	IFpP42/151/1 08/[(18S)3S] E/-10+50/90	IFpP42/151/1 08/[(18S)4S] E/-10+50/90	IFpP42/151/1 08/[(18S)5S] E/-10+50/90	IFpP42/151/1 08/[(18S)6S] E/-10+50/90	IFpP42/151/1 08/[(18S)7S] E/-10+50/90
The number of batteries	1CM+1CS	1CM+2CS	1CM+3CS	1CM+4CS	1CM+5CS	1CM+6CS
Normal voltage (V)	115.2	172.8	230.4	288	345.6	403.2
Normal capacity (Ah)	69	69	69	69	69	69
Normal energy (kWh)	7.95	11.92	15.90	19.87	23.85	27.82
Battery voltage range(V)	97.2~131.4	145.8~197.1	194.4~262.8	243~328.5	291.6~394.2	340.2~459.9
Max. charge/discharge	50/50					

current (A)						
(CC-CV) Standard charging current (A)	35					
Constant current and constant voltage charging cut-off current (A)	3.5					
Peak discharge Current (60s) (A)	65					
Storage temperature (°C)	-20 ~55					
Operating Temperature range (°C)	Charge: 0~55 Discharge: -10~55					
Discharge capacity (Ah)	55@-20±2°C @0.5C 69@25±2°C @0.5C 69@55±2°C @0.5C					
Cycle life	≥6000 @25°C @ 70%SOH					
Ingress protection	IP65					
Protective class	Class I					
Dimensions (L*W*H) (mm)	570*380*350	570*380*470	570*380*590	570*380*710	570*380*830	570*380*950
Weight (kg)	75.5	110.5	145.5	180.5	215.5	250.5
Communication interfaces	CAN					

2.2 System Installation Requirement

2.2.1 System Installation Space

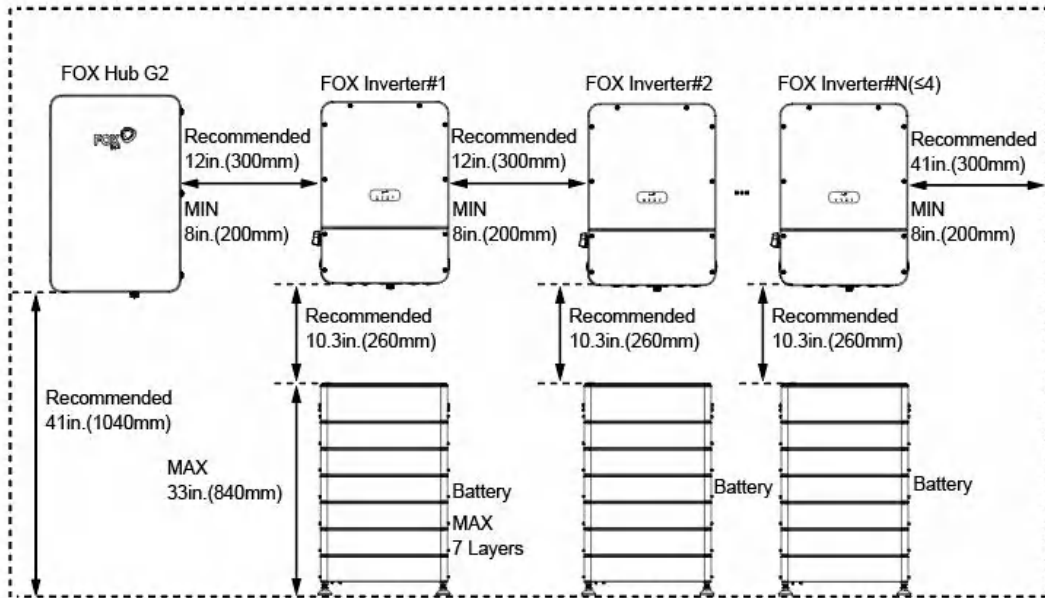

 **Note!**
The recommended installation height of the FOX Hub G2 is 41 in. (1040 mm).

2.2.2 Installing FOX Hub G2 as Service Panel or not as Service Panel

- ① When the FOX Hub G2 is used as the service panel,
 - a. main breaker (Eaton CSR2200N) and line side barriers (Eaton TICSR300C) need to be installed;

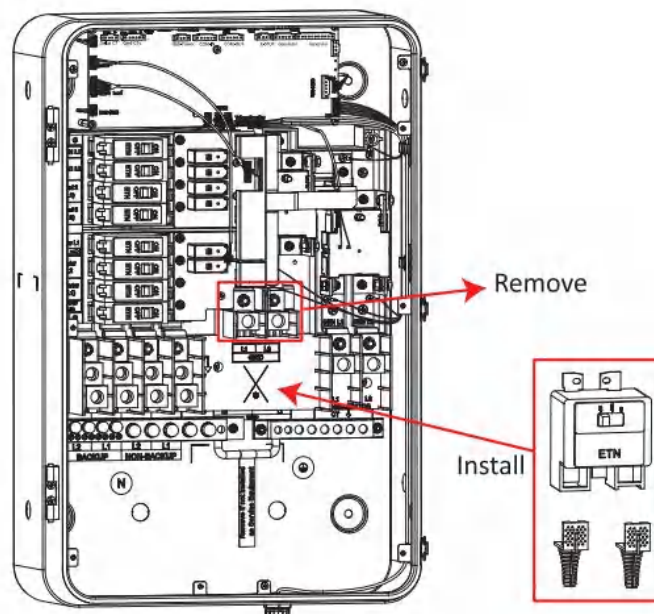

- b. labels of “SERVICE DISCONNECT” and “SUITABLE FOR USE AS SERVICE EQUIPMENT ONLY IN USA WHEN EQUIPPED WITH MAIN BREAKER” shall be applied to the black protection cover.

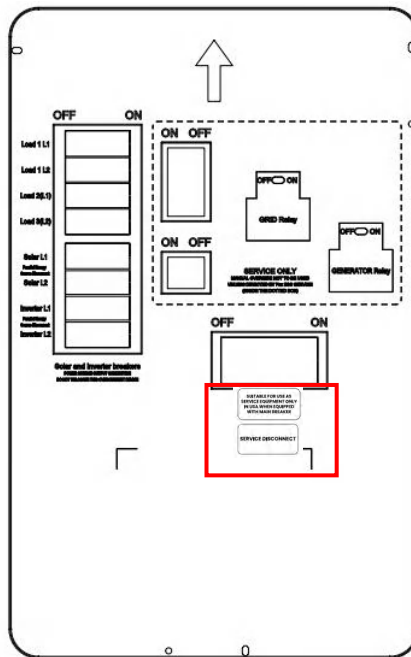

Black Protection Cover

- ② When the FOX Hub G2 is not used as the service panel, bonding jumper needs to be removed.

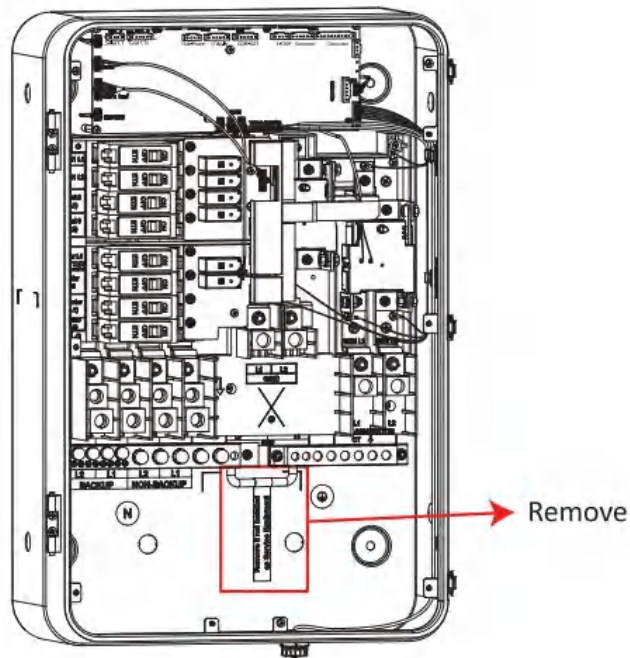

2.3 Backup Options

The backup options of the US Series Energy Storage System include whole-home backup and partial backup. The selection of load for different options should be finalized during the system design phase.

	<p>Note!</p> <p>The standby generator recommended is GENERAC Guardian Series.</p>
---	--

Whole-home Backup

To enable the whole-home backup option, connect all household loads (excluding smart loads) to the backup port of the FOX Hub G2 via the Main Panel. This allows the storage system to support all household energy loads in case of a grid failure.

Whole-home Backup (DC Couple)

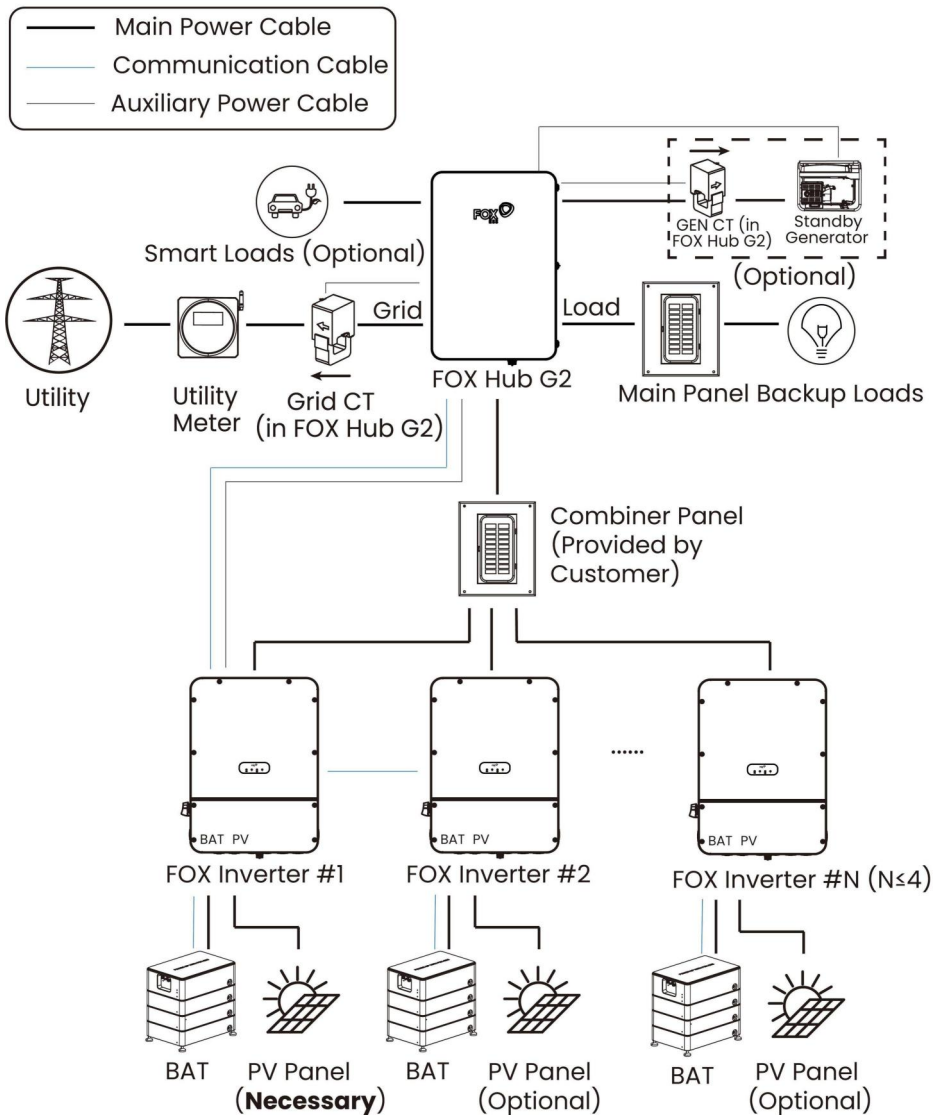

Whole-home Backup (AC Couple)

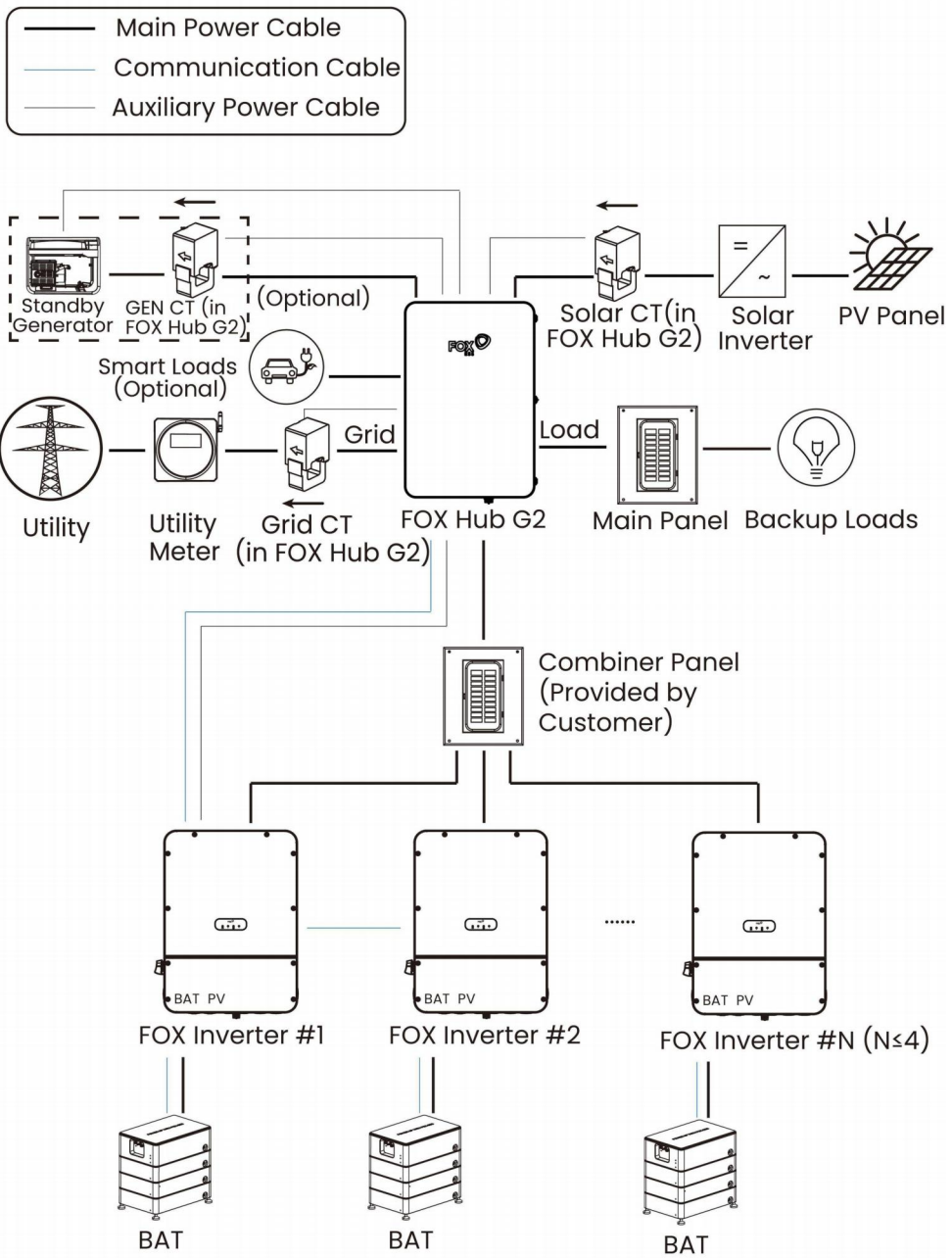

Partial Backup

To configure the system in a partial backup mode, it is necessary to identify the backup loads beforehand. For this purpose, connect the backup loads to the backup panel and the non-backup loads (i.e., non-essential loads) to the main panel. In case of a grid failure, the storage system will only power the backup loads during the outage. This ensures that the backup loads get priority power supply while the non-backup loads remain unpowered.

Partial-home Backup (DC Couple) (FOX Hub G2 as Service Panel)

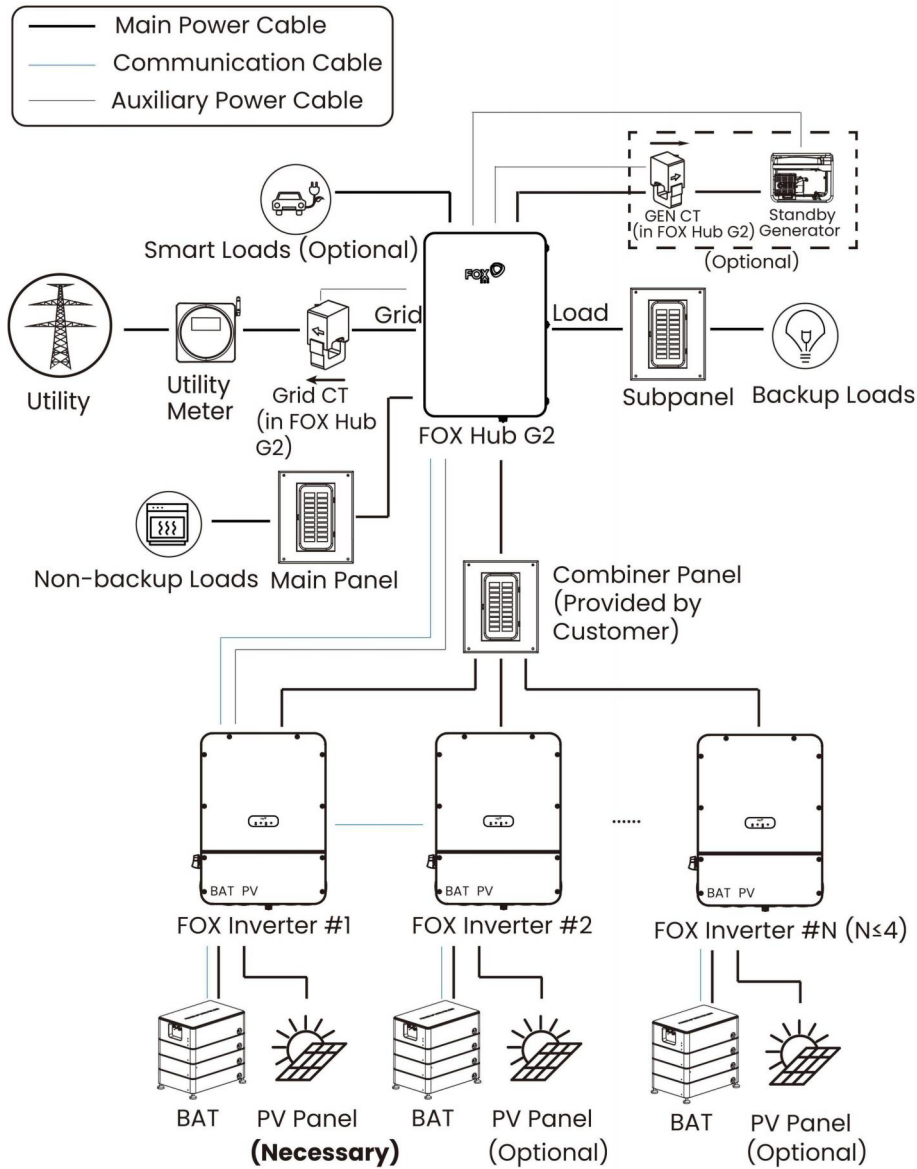

Partial-home Backup (DC Couple) (FOX Hub G2 not as Service Panel)

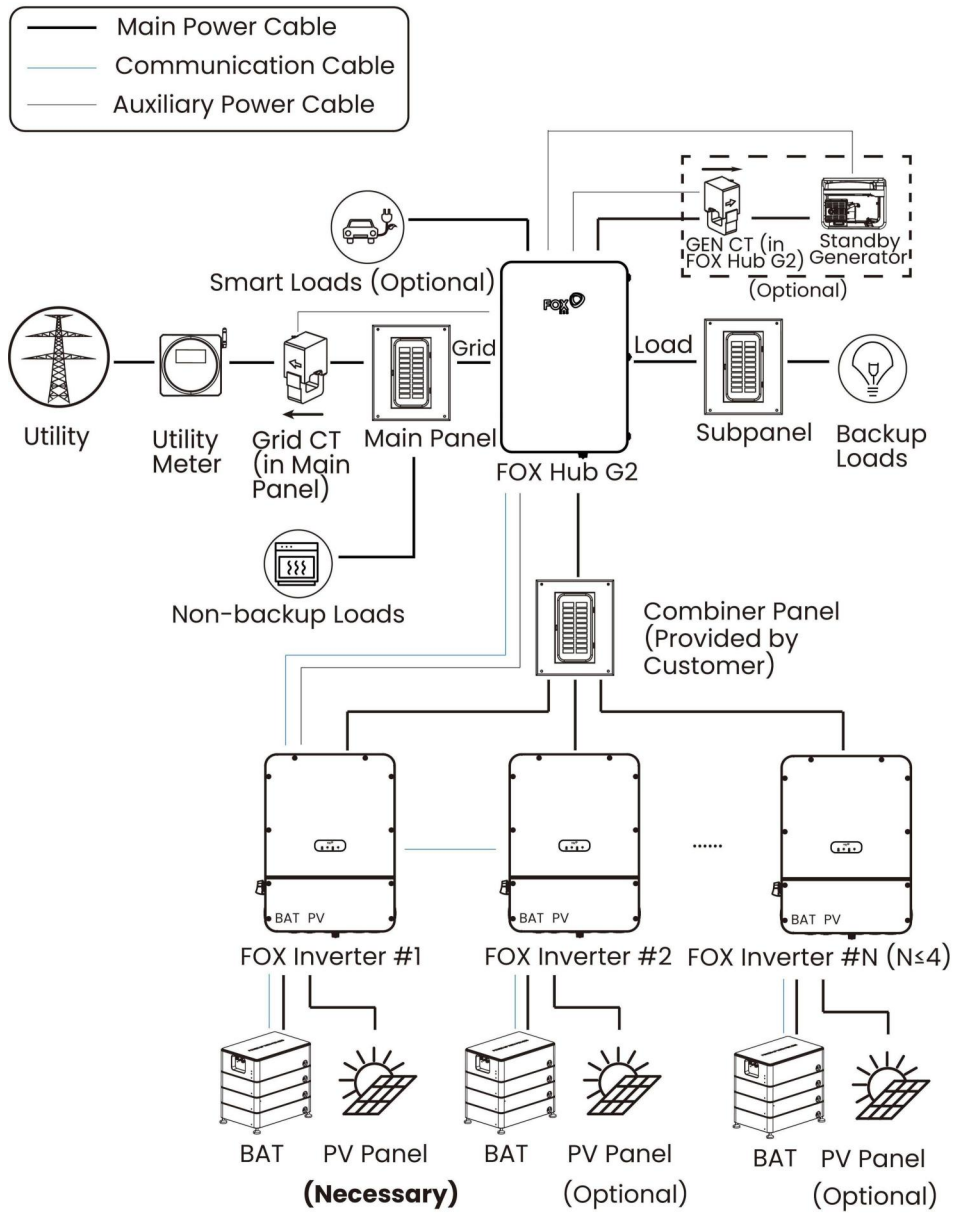

Partial-home Backup (AC Couple) (FOX Hub G2 as Service Panel)

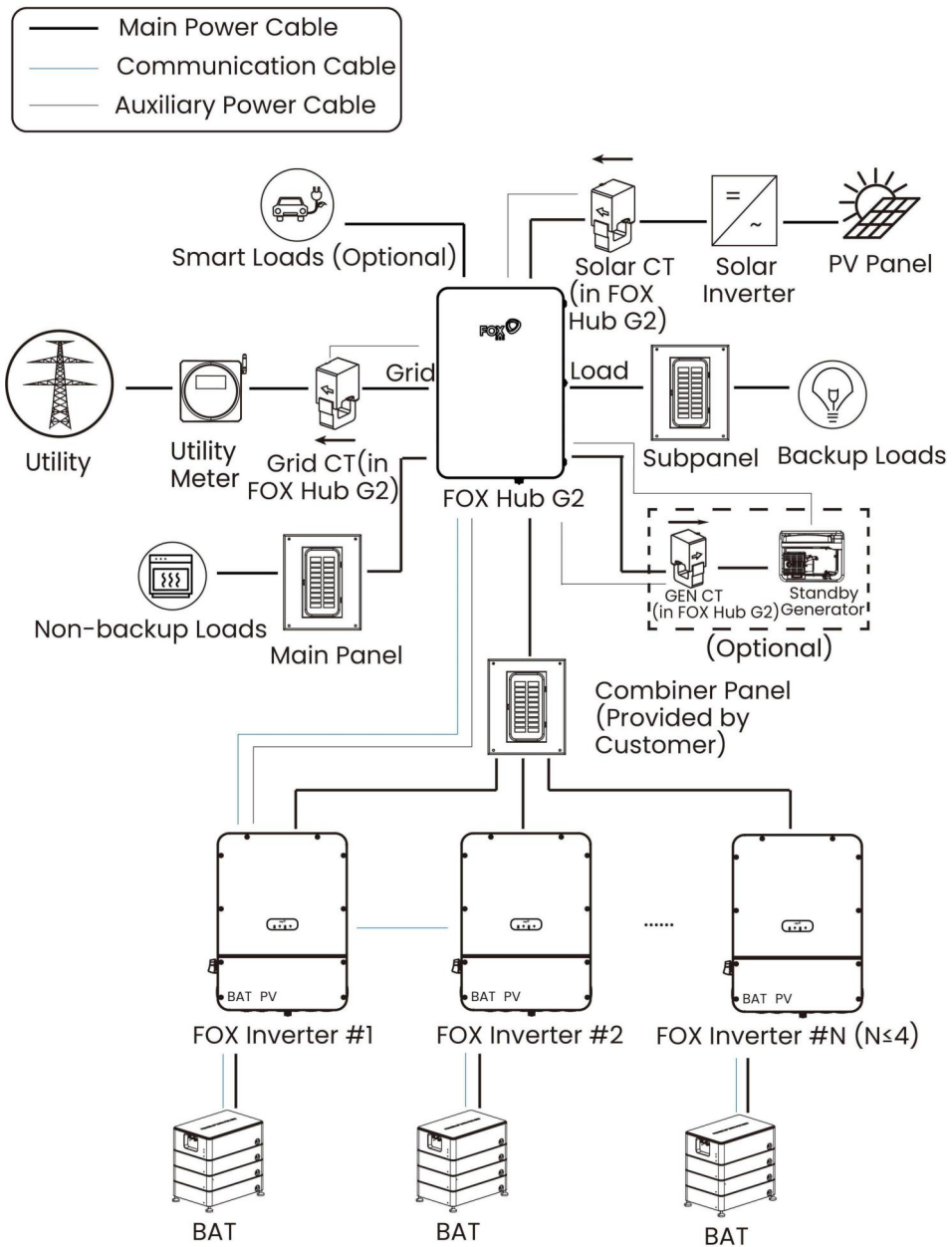

Partial-home Backup (AC Couple) (FOX Hub G2 not as Service Panel)

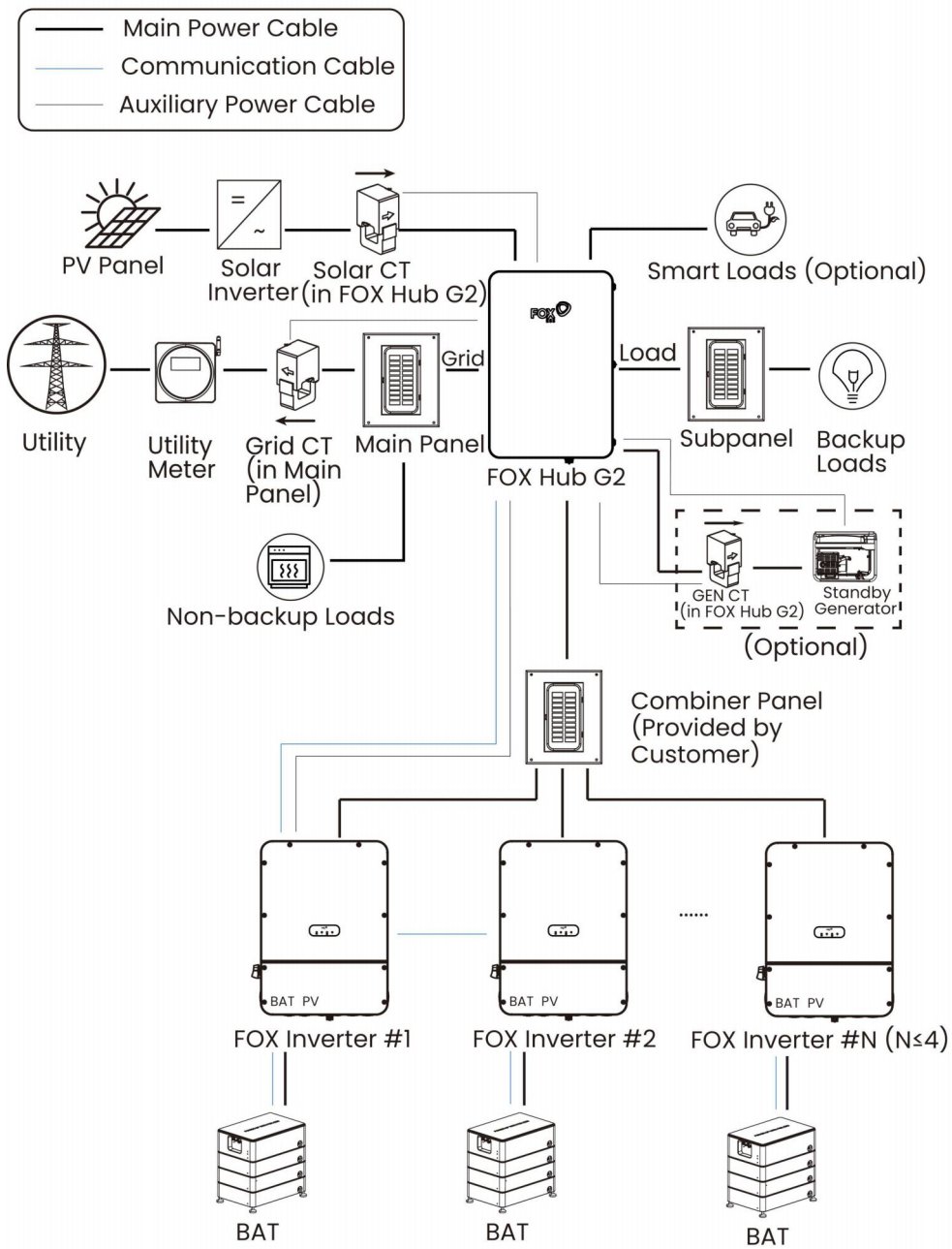

2.4 Operating Mode

The US Series Energy Storage System supports several operating modes, including Mandatory, Self-Power, Time of Use (TOU), and Backup Standby.

Mandatory Mode

When the operating mode is set to the Mandatory, the system will compulsively charge the battery to 100% State of Charge (SOC) from solar and the grid, or discharge the battery to power for the household loads or grid.

Self-Power Mode

When the operating mode is set to the Self-Power, the system is designed to store any surplus electricity generated by the solar system after meeting the power requirements of the household loads. In situations where the solar production is insufficient to meet the total household load, the system will provide additional power support by discharging stored energy, thereby reducing the dependency on grid electricity. If the backup reserve's State of Charge (SOC) is set to 100%, the system will prioritize charging the battery to its maximum capacity exclusively from solar power and will not discharge energy. In the event of a grid failure, the system will automatically switch to powering the household loads using the stored energy.

Time of Use (TOU) Mode

If the electricity rate in the homeowner's area changes throughout the day, based on demand, the homeowner can select the TOU mode to customize the on-peak and off-peak times according to the electricity rate. During the on-peak times, when the electricity rates are higher, the system will prioritize the utilization of solar power and energy stored in the batteries. Throughout the off-peak periods, when electricity rates are lower, the system will utilize a combination of power sources including the grid, the PV system, and the batteries in an optimized manner to meet the household loads.

If the SOC value of the backup reserve is set 100%, during the off-peak periods, the system will focus on charging the batteries to their full capacity using solar power and will not discharge any energy. In the event of a grid failure, the system will automatically switch to powering the household loads.

- **Peak:** highest electric power price
- **Off-peak:** lowest electric power price
- **Shoulder:** the rest hours

TOU provides users with two options:

- Solar power to storage first
- Solar power to family loads first

Functional Logic of TOU Mode			
Charging/Discharging	Electricity Rate	Storage First	Family Loads First
Charging	Peak	The solar power will be prioritized to power the home, while the excess will charge the BAT.	The solar power will be prioritized to power the home, while the excess will charge the BAT.

	Off-peak	The solar power will be prioritized to charge the BAT, while the excess will power the home.	The solar power will be prioritized to charge the BAT, while the excess will power the home.
	Shoulder	The solar power will be prioritized to charge the BAT, while the excess will power the home.	The solar power will be prioritized to power the home, while the excess will charge the BAT.
Discharging	Peak	Power supply priority: Solar > BAT > Grid	
	Off-peak	The BAT does not discharge.	
	Shoulder	The BAT does not discharge.	Power supply priority: Solar > BAT > Grid

Backup Standby Mode

The system prioritizes charging the battery from the PV and the grid until it is fully charged. Once the battery is fully charged, the load energy is supplied by both the PV and the grid.

In the event of a grid failure, the battery will automatically power the household loads. Once the grid power is restored, the system will seamlessly transition back to charging the battery from both solar and the grid.

2.5 Key Functions

Emergency Stop

In an emergency, manually turn off the E-STOP switch, if installed. Otherwise remove the E-STOP switch. The US Series Energy Storage System shuts down after the E-STOP is triggered.

	<p>Note! After the emergency shutdown, the home will lose power.</p>
---	---

On-grid to Off-grid

In the event of a grid failure or abnormality, the system will seamlessly transition to off-grid mode. In this mode, the household loads will be powered by a combination of solar energy, a connected generator (if available), and the system itself. The system ensures uninterrupted power supply to the household loads by utilizing these alternative power sources when grid power is not available or reliable.

Off-grid to On-grid

When the grid is restored, the system will automatically switch to on-grid mode. In this mode, the household loads will be powered by a combination of the grid, solar system, generator (if connected), and the US Series Energy Storage System.

Off-grid FW Function

In off-grid operation, when the output power of the photovoltaic system exceeds the maximum power that the energy storage inverter can absorb, the energy storage

inverter will increase the output AC voltage frequency based on the current operating conditions and the rated frequency. The photovoltaic system monitors the AC voltage frequency, and once it exceeds the rated frequency, the photovoltaic system limits the output power, which is known as frequency-active power derating control. This ensures that the system can balance the excess energy generated by the photovoltaic system during off-grid operation and avoids overloading the energy storage system.

Full Charge Protection

When the US Series Energy Storage System is off-grid, the relay in the hybrid inverter will be automatically turned off as soon as one battery is full (SOC=100%). After the US Series Energy Storage System meets the recovery conditions, the relay in the hybrid inverter will be automatically turned on.

Automatic Black Start

When solar power is insufficient, the grid power is unavailable, and the battery's available power is depleted, the smart loads will be automatically disconnected and the system will enter sleep mode, awaiting a black start attempt.

The system will initiate automatic start-up at predetermined times every day. In case of sufficient solar energy supply, the electricity generated by the photovoltaic system will charge the battery. However, if the solar power is insufficient, the system will return to sleep mode, awaiting the next scheduled automatic start-up.

Smart Loads

The US Series energy storage system provides three smart loads which can be controlled with the FoxCloud US app based on their personalized needs. This helps minimize household expenses while on-grid and saves battery consumption while off-grid.

On-grid

Based on local peak-valley settings and personal habits (such as pumping water into the swimming pool or charging the EVs), users may set a time plan for economical power usage through the FoxCloud US app. One or two time periods may be set for every 24 hours, to achieve the most economical use of electricity for smart loads.

Off-grid

Users may control the on/off status of smart loads by creating a time plan and setting a State of Charge (SOC) threshold. Users may set a SOC threshold (between 10% and 100%) based on the backup sustainability of the smart loads on the FoxCloud US app, where a lower SOC value means a longer backup period for the smart load. When the actual SOC falls below the set threshold, or the time is outside the time period set in the time plan, the smart load will be turned OFF.

The smart loads will not be reconnected until the system actual SOC is 10% higher than the SOC threshold. For example, if the SOC threshold is set to 25%, the smart loads will not be reconnected until SOC reaches 35%.

Manual Control

Users may control the on/off status of the smart loads through the FoxCloud US app. The manual control of the smart loads on/off status has higher operation priority, so that the current time schedule can be overridden, disabled, and

reactivated in the next time period.

The smart loads module can remotely control the on/off status of three smart loads, which may be set and controlled separately. Smart load 1 is only used for 240V loads without a neutral wire. No device requiring a neutral wire should be connected to smart load 1. Smart load 2 and smart load 3 may be set flexibly based on user needs and the configuration on the FoxCloud US app.

**Note!**

Circuit breaker cannot be relied on to provide overload protection when installed below 0 degree C. Separated overload protection shall be provided as required CEC and NEC if ambient temperature is below 0 degree C.

3 System Remote Operation and Monitoring

The FoxCloud US app provides remote operation and monitoring of the whole house energy system. It allows personalized household electricity plans to make your life easier.

The home screen of the FoxCloud US app displays real-time data from the US Series Energy Storage System to help you understand the working status of your home power system. Please scan the following QR code to refer to **the FoxCloud US App User Manual** for more information.

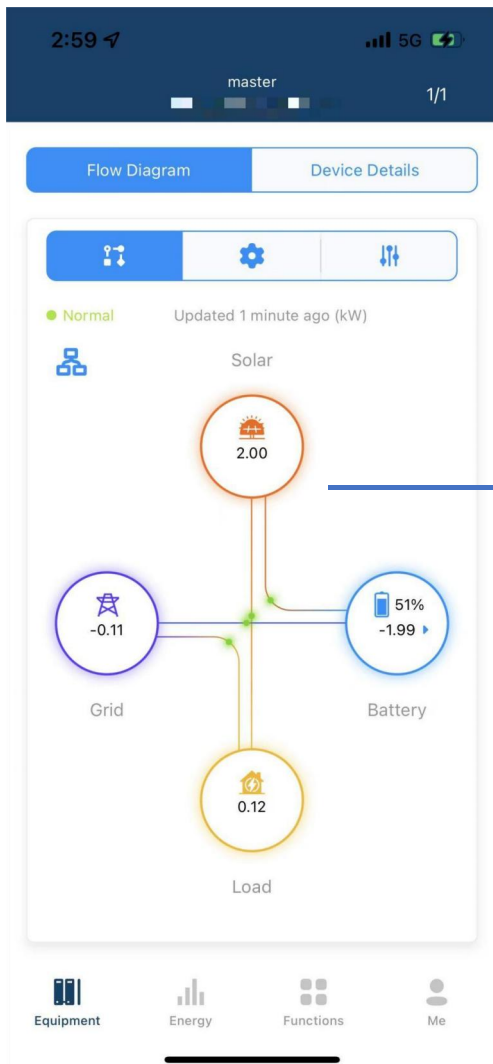

The working status of each energy source in the home.

4 Service and Maintenance

This section contains information and procedures for solving possible problems with the US Series Energy Storage System and provides you with troubleshooting tips to identify and solve most problems that can occur.

4.1 Troubleshooting

Item	Alarm Number	Alarm Name	Alarm Severity	Alarm Action	Possible Cause	Suggestion
1	1025	Grid Overvoltage	Major	Shutdown, alarm reporting, and automatic recovery after the fault is rectified.	The grid voltage RMS value exceeds the higher threshold specified for HVRT.	<ol style="list-style-type: none"> 1. If the alarm is triggered accidentally, it may be due to temporary abnormalities in the power grid. The inverter will automatically recover after the power grid has resumed normal functioning. 2. Check whether the grid connection voltage exceeds the upper threshold. If so, contact the local power operator. 3. If you have confirmed that the grid connection voltage exceeds the upper threshold and have obtained the consent of the local power operator, modify the overvoltage protection threshold.
2	1026	Grid Transient Overvoltage	Major	Shutdown, alarm reporting, and automatic recovery after the fault is rectified.	The grid voltage peak value exceeds the higher threshold specified for HVRT.	<ol style="list-style-type: none"> 1. If the alarm is triggered accidentally, it may be due to temporary abnormalities in the power grid. The inverter will automatically recover after the power grid has resumed normal functioning. 2. If the alarm is triggered frequently, check whether the grid voltage is within the acceptable range. If not, contact the local power operator. If so, modify the power grid overvoltage protection threshold with the consent of the local power operator.

Item	Alarm Number	Alarm Name	Alarm Severity	Alarm Action	Possible Cause	Suggestion
3	1027	Grid Undervoltage	Major	Shutdown, alarm reporting, and automatic recovery after the fault is rectified.	The grid voltage rms value is below the lower threshold specified for LVRT.	<ol style="list-style-type: none"> 1. If the alarm is triggered accidentally, it may be due to temporary abnormalities in the power grid. The inverter will automatically recover after the power grid has resumed normal functioning. 2. If the alarm is triggered frequently, check whether the grid voltage is within the acceptable range. If not, contact the local power operator. If so, modify the power grid undervoltage protection threshold with the consent of the local power operator. 3. If the fault persists for a long time, check the connection between the AC switch and the output power cable.
4	1028	Grid Voltage Low	Major	Shutdown, alarm reporting, and automatic recovery after the fault is rectified.	The grid voltage rms value is below the lower threshold specified for LVRT.	<ol style="list-style-type: none"> 1. If the alarm is triggered accidentally, it may be due to temporary abnormalities in the power grid. The inverter will automatically recover after the power grid has resumed normal functioning. 2. If the alarm is triggered frequently, check whether the grid voltage is within the acceptable range. If not, contact the local power operator. If so, modify the power grid undervoltage protection threshold with the consent of the local power operator. 3. If the fault persists for a long time, check the connection between the AC switch and the output power cable.

Item	Alarm Number	Alarm Name	Alarm Severity	Alarm Action	Possible Cause	Suggestion
5	1030	AC Overcurrent	Major	Shutdown, alarm reporting, and automatic recovery after the fault is rectified.	The grid voltage drops dramatically or the power grid or the output load is short-circuited. As a result, the inverter transient output current exceeds the upper threshold and, which triggers the inverter protection.	<ol style="list-style-type: none"> 1. The inverter monitors its external working conditions in real time. And it can automatically recover after the fault is rectified. 2. If the alarm is triggered frequently and affects the power production of the PV plant, check whether grid or the output is short-circuited. If the fault persists, contact your installer.
6	1031	Grid Overfrequency	Major	Shutdown, alarm reporting, and automatic recovery after the fault is rectified.	The actual grid frequency is higher than the local power grid standard.	<ol style="list-style-type: none"> 1. If the alarm is triggered accidentally, it may be due to temporary abnormalities in the power grid. The inverter will automatically recover after the power grid has resumed normal functioning. 2. If the alarm is triggered frequently, check whether the grid frequency is within the acceptable range. If not, contact the local power operator. If so, modify the grid overfrequency protection threshold with the consent of the local power operator.
7	1032	Grid Underfrequency	Major	Shutdown, alarm reporting, and automatic recovery after the fault is rectified.	The actual grid frequency is below than lower threshold standard.	<ol style="list-style-type: none"> 1. If the alarm is triggered accidentally, it may be due to temporary abnormalities in the power grid. The inverter will automatically recover after the power grid has resumed normal functioning. 2. If the alarm is triggered frequently, check whether the grid frequency is within the acceptable range. If not, contact the local power operator. If so, modify the grid underfrequency protection threshold with the consent of the local power operator.

Item	Alarm Number	Alarm Name	Alarm Severity	Alarm Action	Possible Cause	Suggestion
8	1035	High Leakage Current Fault	Major	Shutdown, alarm reporting, and automatic recovery after the fault is rectified.	The leak current RMS value exceeds the threshold specified for leak current, and the temporary dynamic value exceeds 30mA over 0.3s, or exceeds 60mA 0.15s or 150mA 0.04s.	<ol style="list-style-type: none"> 1. If the alarm is triggered accidentally, it may be due to leak current exceeding the threshold or temporary dynamic value exceeding the threshold. The inverter will automatically recover when the leak current is less than 100mA. 2. If the alarm is triggered frequently and affects the power production of the PV plant, check ground impedance of PV. If the fault persists, contact your installer.
9	1038	Grid Voltage High	Major	Shutdown, alarm reporting, and automatic recovery after the fault is rectified.	The grid voltage RMS value exceeds the higher threshold specified for HVRT.	<ol style="list-style-type: none"> 1. If the alarm is triggered accidentally, it may be due to temporary abnormalities in the power grid. The inverter will automatically recover after the power grid has resumed normal functioning. 2. Check whether the grid connection voltage exceeds the upper threshold. If so, contact the local power operator. 3. If you have confirmed that the grid connection voltage exceeds the upper threshold and have obtained the consent of the local power operator, modify the overvoltage protection threshold.
10	1039	Hardware (L1) Inverter Overcurrent Fault	Major	Shutdown, alarm reporting, and automatic recovery after the fault is rectified.	The grid voltage drops dramatically or the power grid or the output load is short-circuited. As a result, the inverter transient output current exceeds the upper threshold and,	<ol style="list-style-type: none"> 1. The inverter monitors its external working conditions in real time. And it can automatically recover after the fault is rectified. 2. If the alarm is triggered frequently and affects the power production of the PV plant, check whether grid or the output is overloaded or short-circuited. If the fault persists, contact your installer.

Item	Alarm Number	Alarm Name	Alarm Severity	Alarm Action	Possible Cause	Suggestion
					which triggers the inverter protection.	
11	1040	Unbalanced Grid Voltage	Major	Shutdown, alarm reporting, and automatic recovery after the fault is rectified.	The difference between grid phase voltages exceeds the upper threshold.	<ol style="list-style-type: none"> 1. Check that the grid voltage is within the normal range. 2. Check the connection of the AC output power cable. 3. If the cable is connected properly but the alarm is triggered frequently and affects the power production of the PV plant, contact the local power operator.
12	1041	Hardware (L2) Inverter Overcurrent Fault	Major	Shutdown, alarm reporting, and automatic recovery after the fault is rectified.	The grid voltage drops dramatically or the power grid or the output load is short-circuited. As a result, the inverter transient output current exceeds the upper threshold and, which triggers the inverter protection.	<ol style="list-style-type: none"> 1. The inverter monitors its external working conditions in real time. And it can automatically recover after the fault is rectified. 2. If the alarm is triggered frequently and affects the power production of the PV plant, check whether grid or the output is overloaded or short-circuited. If the fault persists, contact your installer.
13	1042	Grid Frequency High	Major	Shutdown, alarm reporting, and automatic recovery after the fault is rectified.	The actual grid frequency is higher than the local power grid standard.	<ol style="list-style-type: none"> 1. If the alarm is triggered accidentally, it may be due to temporary abnormalities in the power grid. The inverter inverter will automatically recover after the power grid has resumed normal functioning. 2. If the alarm is triggered frequently, check whether the grid frequency is within the acceptable range. If not, contact the local power operator. If so, modify the grid overfrequency protection threshold with the consent of the local power operator.

Item	Alarm Number	Alarm Name	Alarm Severity	Alarm Action	Possible Cause	Suggestion
14	1043	Grid Frequency Low	Major	Shutdown, alarm reporting, and automatic recovery after the fault is rectified.	The actual grid frequency is below than the local power grid standard.	<ol style="list-style-type: none"> 1. If the alarm is triggered accidentally, it may be due to temporary abnormalities in the power grid. The inverter will automatically recover after the power grid has resumed normal functioning. 2. If the alarm is triggered frequently, check whether the grid frequency is within the acceptable range. If not, contact the local power operator. If so, modify the grid underfrequency protection threshold with the consent of the local power operator.
15	1047	Ground Wire Detection Fault	Major	Shutdown, alarm reporting, and automatic recovery after the fault is rectified.	<ol style="list-style-type: none"> 1. The PE cable for the inverter is not connected. 2. The voltage between the inverter neutral wire and ground exceeds the upper threshold. 	<ol style="list-style-type: none"> 1. Check whether the PE cable for the inverter is connected properly. 2. Check whether the output is connected to an isolation transformer. If so, set OFF due to abnormal grounding to Disable. 2. If the inverter is connected to the TN power grid, check whether the voltage of the neutral wire to ground is normal.
16	1057	Bus Transient Overvoltage	Major	Shutdown, alarm reporting, and automatic recovery after the fault is rectified.	Bus voltage is higher than the value of protection.	<ol style="list-style-type: none"> 1. If the alarm is triggered accidentally, it may be due to temporary abnormalities in the power grid. The inverter will automatically recover after the power grid resumes normal functioning. 2. Check the PV open voltage if higher than 550V. 3. Check the BAT voltage if higher than 460V. 4. If the fault persists, contact your installer.

Item	Alarm Number	Alarm Name	Alarm Severity	Alarm Action	Possible Cause	Suggestion
17	1066	DC Input PV1 Reverse Connection Fault	Major	Shutdown, alarm reporting, and automatic recovery after the fault is rectified.	The PV1 module output is reversely connected.	Check whether the PV1 module output is reversely connected.
18	1067	DC Input PV2 Reverse Connection Fault	Major	Shutdown, alarm reporting, and automatic recovery after the fault is rectified.	The PV2 module output is reversely connected.	Check whether the PV2 module output is reversely connected.
19	1081	DC Input PV3 Reverse Connection Fault	Major	Shutdown, alarm reporting, and automatic recovery after the fault is rectified.	The PV3 module output is reversely connected.	Check whether the PV3 module output is reversely connected.
20	1089	INV IGBT Overtemperature	Major	Shutdown, alarm reporting, and automatic recovery after the fault is rectified.	The temperature of INV IGBT is higher than the threshold. 1. The inverter is installed in a place with poor ventilation. 2. The ambient temperature exceeds the upper threshold. 3. The inverter is not working properly.	1. Check the ventilation and ambient temperature at the inverter installation position. 2. If the ventilation is poor or the ambient temperature exceeds the upper threshold, improve the ventilation and heat dissipation. 3. If the ventilation and ambient temperature both meet requirements, contact your installer.
21	1095	E-STOP Trigger	Major	Shutdown, alarm reporting, and automatic recovery after the fault is rectified.	Emergency Stop Switch triggered.	1. Check the Emergency Stop Switch if it is pushed. 2. Check the Emergency Stop Switch cable if the Emergency Stop Switch is open. 3. Check whether the Emergency Stop Switch cable is connected to the correct connector of the

Item	Alarm Number	Alarm Name	Alarm Severity	Alarm Action	Possible Cause	Suggestion
						inverter. 4. If the fault persists, contact your installer.
22	1109	Leak Current CT Self-checking Fault	Major	Shutdown, alarm reporting, and automatic recovery after the fault is rectified.	Residual Current CT check failure. The insulation impedance of the input side to PE decreased.	1. If it is triggered accidentally, the external power cable may be abnormal temporarily. The inverter automatically recovers after the fault is rectified. 2. If the alarm is triggered frequently or persists, check that the impedance between the PV string and ground is not below the lower threshold.
23	1122	Ambient Overtemperature	Major	Shutdown, alarm reporting, and automatic recovery after the fault is rectified.	The inner temperature of inverter is higher than the upper threshold . 1. The inverter is installed in a place with poor ventilation. 2. The ambient temperature exceeds the upper threshold. 3. The inverter is not working properly.	1. Check the ventilation and ambient temperature at the inverter installation position. 2. If the ventilation is poor or the ambient temperature exceeds the upper threshold, improve the ventilation and heat dissipation. 3. If the ventilation and ambient temperature both meet requirements, contact your installer.
24	1124	Low Insulation Impedance Fault	Major	Shutdown, alarm reporting, and automatic recovery after the fault is rectified.	Low Insulation Resistance is below than the value of protection. 1. The PV string is shorted to PE. 2. The PV string has been operating in a moist environment for a long time.	1. Check the impedance between the PV array output and PE, and eliminate short circuits and poor insulation points. 2. Check whether the inverter PE cable is properly connected. 3. If you are sure that the impedance is less than the value of protection in a cloudy or rainy environment, reset insulation resistance protection.
25	1126	Leak Current Sampling Channel Fault	Major	Shutdown, alarm reporting, and	Residual Current CT check failure. The insulation	1. If it is triggered accidentally, the external power cable may be abnormal temporarily. The inverter

Item	Alarm Number	Alarm Name	Alarm Severity	Alarm Action	Possible Cause	Suggestion
				automatic recovery after the fault is rectified.	impedance of the input side to PE decreased.	automatically recovers after the fault is rectified. 2. If the alarm is triggered frequently or persists, check that the impedance between the PV string and ground is not below the lower threshold.
26	1136	Load Overpower Fault	Major	Shutdown, alarm reporting, and automatic recovery after the fault is rectified.	The power of the Off-Grid Load is higher than the upper threshold in the Off-Grid Mode.	Check if the power of the Off-Grid Load exceeds the permitted value.
27	1137	INV Low Voltage Fault Under Off-grid	Major	Shutdown, alarm reporting, and automatic recovery after the fault is rectified.	The output voltage is below the lower threshold in the Off-Grid Mode.	1. Check if the power of the Off-Grid Load exceeds the permitted value. 2. Check if the output is shorted.
28	1144	Arc Self-checking Fault	Major	Shutdown, alarm reporting, and automatic recovery after the fault is rectified.	The PV string power cable arcs or is in poor contact.	Check whether the string circuit arcs or is in poor contact. After the fault is rectified, manually clear the alarm and then start again.
29	1145	Arc Fault	Major	Shutdown, alarm reporting, and automatic recovery after the fault is rectified.	The sampling circuit of the AFCI circuit is not operating correctly.	Check whether the string circuit arcs or is in poor contact. After the fault is rectified, manually clear the alarm and then start again.
30	1154	INV Overcurrent Permanent Fault	Major	Shutdown, alarm reporting, and automatic recovery after the fault is rectified.	The grid voltage drops dramatically or the power grid or the output load is short-circuited. As a result, the inverter transient	1. The inverter monitors its external working conditions in real time. And it can automatically recover after the fault is rectified. 2. If the alarm is triggered frequently and affects the power production of the PV plant, check

Item	Alarm Number	Alarm Name	Alarm Severity	Alarm Action	Possible Cause	Suggestion
					output current exceeds the upper threshold and, which triggers the inverter protection.	whether grid or the output is overloaded or short-circuited. If the fault persists, contact your installer.
31	1168	INVL2 Overcurrent Permanent Fault	Major	Shutdown, alarm reporting, and automatic recovery after the fault is rectified.	The grid voltage drops dramatically or the power grid or the output load is short-circuited. As a result, the inverter transient output current exceeds the upper threshold and, which triggers the inverter protection.	<ol style="list-style-type: none"> 1. The inverter monitors its external working conditions in real time. And it can automatically recover after the fault is rectified. 2. If the alarm is triggered frequently and affects the power production of the PV plant, check whether grid or the output is overloaded or short-circuited. If the fault persists, contact your installer.
32	1172	Leak Current Permanent Fault	Major	Shutdown, alarm reporting, and automatic recovery after the fault is rectified.	The insulation impedance of the input side to PE decreases when the inverter is operating	<ol style="list-style-type: none"> 1. If the alarm is triggered accidentally, the external power cable may be abnormal temporarily. The inverter automatically recover after the fault is rectified. 2. If the alarm is triggered frequently or persists, check that the impedance between the PV string and ground is not below the lower threshold.
33	1217	Transient Overcurrent during BDC Charging	Major	Shutdown, alarm reporting, and automatic recovery after the fault is rectified.	The Battery DC charge current is higher than the upper threshold. 1. The battery is faulty.	<ol style="list-style-type: none"> 1. If the FAULT indicator on the front of the battery pack is ON or flashing, contact your installer. 2. Check that the communications cable and power cable between the inverter and the battery are properly connected. 2. Send a shutdown command on the app. Turn off the AC output switch, DC input switch, and battery switch in order, and then turn on the battery switch, AC output switch, and DC input switch in sequence after 5 minutes.

Item	Alarm Number	Alarm Name	Alarm Severity	Alarm Action	Possible Cause	Suggestion
						3. If the alarm still exists, contact your installer.
34	1218	Transient Overcurrent during BDC Discharging	Major	Shutdown, alarm reporting, and automatic recovery after the fault is rectified.	The Battery DC discharge current is higher than the upper threshold. 1. The battery is faulty. 2. The battery SOC is too low.	1. If the FAULT indicator on the front of the battery pack is ON or flashing, contact your installer. 2. Check that the communications cable and power cable between the inverter and the battery are properly connected. 3. Send a shutdown command on the app. Turn off the AC output switch, DC input switch, and battery switch in order, and then turn on the battery switch, AC output switch, and DC input switch in sequence after 5 minutes. 4. If the alarm still exists, contact your installer.
35	1229	BDC Overtemperature Fault	Major	Shutdown, alarm reporting, and automatic recovery after the fault is rectified.	The temperature of battery DC IGBT is higher than the upper threshold. 1. The inverter is installed in a place with poor ventilation. 2. The ambient temperature exceeds the upper threshold. 3. The inverter is not working properly.	1. Check the ventilation and ambient temperature at the inverter installation position. 2. If the ventilation is poor or the ambient temperature exceeds the upper threshold, improve the ventilation and heat dissipation. 3. If the ventilation and ambient temperature both meet requirements, contact your installer.
36	1242	BDC Average Low Voltage Fault (Total battery voltage is below undervoltage value in non-charging mode)	Major	Shutdown, alarm reporting, and automatic recovery after the fault is rectified.	1. The battery is faulty.	1. If the FAULT indicator on the front of the battery pack is ON or flashing, contact your installer. 2. Check that the communications cable and power cable between the inverter and the battery are properly connected. 2. Send a shutdown command on the app. Turn off the AC output switch, DC input switch, and battery

Item	Alarm Number	Alarm Name	Alarm Severity	Alarm Action	Possible Cause	Suggestion
						switch in order, and then turn on the battery switch, AC output switch, and DC input switch in sequence after 5 minutes. 3. If the alarm still exists, contact your installer.
37	1247	Reversed Battery Polarity Connection Fault	Major	Shutdown, alarm reporting, and automatic recovery after the fault is rectified.	The battery output is reversely connected.	Check whether the battery output is reversely connected.
38	1248	BDC Overload Fault	Major	Shutdown, alarm reporting, and automatic recovery after the fault is rectified.	1. The battery is faulty. 2. The battery SOC is too low.	1. Check that the communications cable and power cable between the inverter and the battery are properly connected. 2. Send a shutdown command on the app. Turn off the AC output switch, DC input switch, and battery switch in order, and then turn on the battery switch, AC output switch, and DC input switch in sequence after 5 minutes. 3. If the alarm still exists, contact your installer.
39	1281	Communication Fault between Communication Board and Main DSP	Minor	Alarm reporting	1. The communication cables are not connected properly. 2. The communication is interfered.	1. Turn off the AC output switch, DC input switch, and battery switch in order, and then turn on the battery switch, AC output switch, and DC input switch in sequence after 2 minutes. 2. If the fault still exists, contact your installer.
40	1283	Communication Fault between Communication Board and BMS	Minor	Alarm reporting	1. The communication cables are not connected well. 2. The communication cables are too long or do not use	Shut down the battery and check the communication cables and power cable between the FOX Inverter and the battery are properly connected.

Item	Alarm Number	Alarm Name	Alarm Severity	Alarm Action	Possible Cause	Suggestion
					shielded twisted pair with drain wire.	
41	1284	Communication Fault between Communication Board and Built-in Meter	Minor	Alarm reporting	The RS485 communication cables of the Built-in Meter are not properly connected.	<ol style="list-style-type: none"> 1. Turn off the AC output switch, DC input switch, and battery switch in order, and then turn on the battery switch, AC output switch, and DC input switch in sequence after 2 minutes. 2. If the fault still exists, contact your installer.
42	1285	Communication Fault between Communication Board and Grid Meter	Minor	Alarm reporting	The RS485 communication cables of the Grid Meter are not properly connected.	Check that the communications cable and power cable between the inverter and the Meter are properly connected.
43	1286	Communication Board Flash Writing Fault	Minor	Alarm reporting	<ol style="list-style-type: none"> 1. The Flash IC is interfered. 2. Flash IC fails. 	<ol style="list-style-type: none"> 1. Turn off the AC output switch, DC input switch, and battery switch in order, and then turn on the battery switch, AC output switch, and DC input switch in sequence after 2 minutes. 2. If the fault still exists, contact your installer.
44	1287	RTC Read-Write Fault	Minor	Alarm reporting	The RTC communication is interfered.	<ol style="list-style-type: none"> 1. Turn off the AC output switch, DC input switch, and battery switch in order, and then turn on the battery switch, AC output switch, and DC input switch in sequence after 2 minutes. 2. If the fault still exists, contact your installer.
45	1288	Communication Fault between Communication Board and HUB Board	Minor	Shutdown, alarm reporting, and automatic recovery after the fault is rectified.	<ol style="list-style-type: none"> 1. The RS485 communication cables are not properly connected. 2. The RS485 communication cables are too long or do not use shielded twisted pair with drain wire. 	<ol style="list-style-type: none"> 1. Check whether the RS485 communication cable between FOX Inverter and FOX Hub G2, also between FOX Inverters, are properly connected. 2. Check whether the length of the communication cable exceeds the upper threshold in the specification. and whether it is shielded twisted pair with drain wire.

Item	Alarm Number	Alarm Name	Alarm Severity	Alarm Action	Possible Cause	Suggestion
						<p>3. Turn off the AC output switch, DC input switch, and battery switch in order, and then turn on the battery switch, AC output switch, and DC input switch in sequence after 2 minutes.</p> <p>4. If the fault still exists, contact your installer.</p>
46	1289	Solar Meter Communication Fault	Minor	Alarm reporting	The RS485 communication cables of the Solar Meter are not properly connected.	Check the RS485 communication cables of the Solar Meter are properly connected.
47	1290	GEN Meter Communication Fault	Minor	Alarm reporting	The RS485 communication cables of the GEN Meter are not properly connected.	Check whether the RS485 communication cables of the GEN Meter are properly connected.



Note!

If the installer issued a remote shutdown command (key off) in a certain situation while the system was working in an off-grid mode, this will result in a power outage and loss of WiFi connection at the user's home. The installer is unable to restore the system remotely. In this case, the installer needs to contact the user to manually restore the system following these steps: press the E-STOP button and wait for 3 seconds; then rotate the button clockwise to release it. If the E-STOP button is released too late, it may cause a complete power loss of the inverter's auxiliary power supply. In such cases, a black start is required to power on the system (detailed instructions can be found in the Installation Guide).

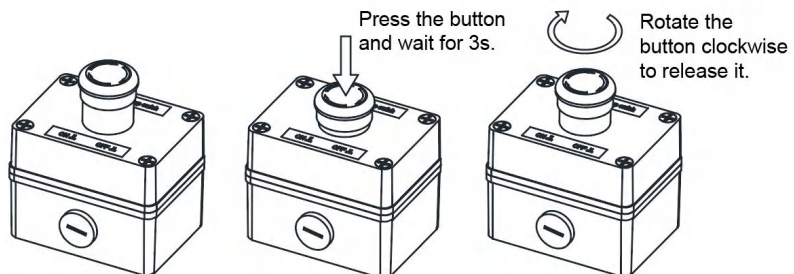

4.2 Service and Maintenance

• **Service**

- Keep the hybrid inverter clear of any leaves or foreign objects, particularly avoiding

their presence on top of the unit or between the unit and the back wall.

- Keep the hybrid inverter away from the direct sunlight.
- Keep all the equipment in an environment with acceptable temperature and humidity.
- Clean the equipment surface using a soft cloth. If necessary, lightly dampen the cloth with water (only) and ensure that the equipment is fully powered off before cleaning.
- Do not block the vents.
- Maintain a safe distance between all units and substances that are flammable, explosive, or toxic.
- Keep the equipment operating within the allowed power range and avoid overloading.
- Verify that all cables are securely connected and all connectors are free from stress.
- Maintain a safe distance between the equipment and hazardous areas or potential risks.

- **Maintenance**

- Please check the running status of your equipment on your mobile app. If any alarm is found, please contact the qualified service group.
- Do not attempt to repair the system by yourself. Contact the professionals qualified by Fox ESS.
- If the problem cannot be solved via the above solution, contact Fox ESS customer service for further assistance. Please be prepared to describe details of your system installation and provide the model and serial number of the unit.

5 Decommissioning

5.1 Dismantling the US Series Energy Storage System

- Turn off the PV/DC switch, battery, AC breakers, and off-grid breaker of the FOX Hub G2. Wait for 5 minutes for the hybrid inverter and the FOX Hub G2 to fully de-energize.
- Disconnect communication and optional connection wirings. Remove the hybrid inverter and the FOX Hub G2 from the bracket.
- Remove the bracket if necessary.

5.2 Packaging

If possible, please pack the hybrid inverter, the FOX Hub G2, and the battery with the original packaging. If it is no longer available, you can also use an equivalent box that meets the following requirements.

- Suitable for loads more than 38 kg.
- Contains a handle.
- Can be fully closed.

5.3 Storage and Transportation

Store the hybrid inverter, the FOX Hub G2, and the battery in dry place where ambient temperatures are always between $-40\text{ }^{\circ}\text{C}$ – $+70\text{ }^{\circ}\text{C}$. Take care of the hybrid inverter, the FOX Hub G2, and the battery during the storage and transportation; keep less than 4 cartons in one stack. When the hybrid inverter or other related components need to be disposed of, please ensure it is carried out according to local waste handling regulations. Please be sure to deliver the hybrid inverter, the FOX Hub G2, and the battery that need to be disposed from sites that are appropriate for the disposal in accordance with local regulations.

6 Appendix 1: Fox ESS Three-line Diagram (1 FOX Hub G2+1 INV)

Whole-home Backup (DC Couple)

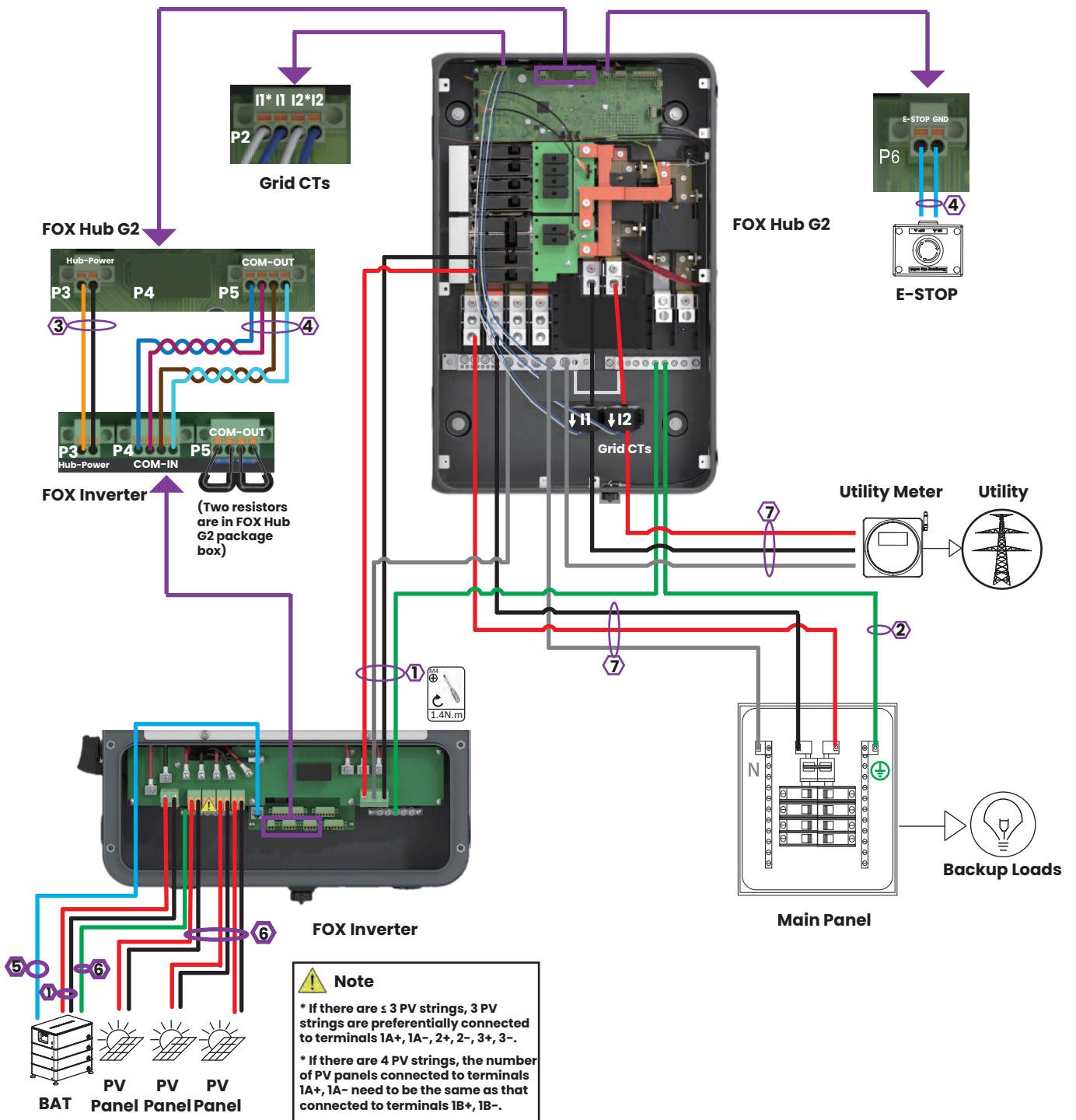

Key

- L1/Negative
- L2/Positive
- Ground
- Neutral

Other Colors: Sensors/Communications

Wire Gauge Guide(copper)		
Label	Input Terminal	Conductor
1	BAT/AC IN/OUT/N/GND	6 AWG
2	AC IN/OUT/N/GND	6-2/0 AWG
3	Power	16 AWG
4	Signal Cable	24-16 AWG
5	Communication Cable	Ethernet Cable
6	MPPT/GND	10 AWG
7	AC IN/OUT/N	6AWG-250 kcmil
8	AC IN/OUT/N	6-4/0 AWG
9	AC IN/OUT	6-1/0 AWG

Fox ESS Three-line Diagram (1 FOX Hub G2+1 INV)

Whole-home Backup (AC Couple)

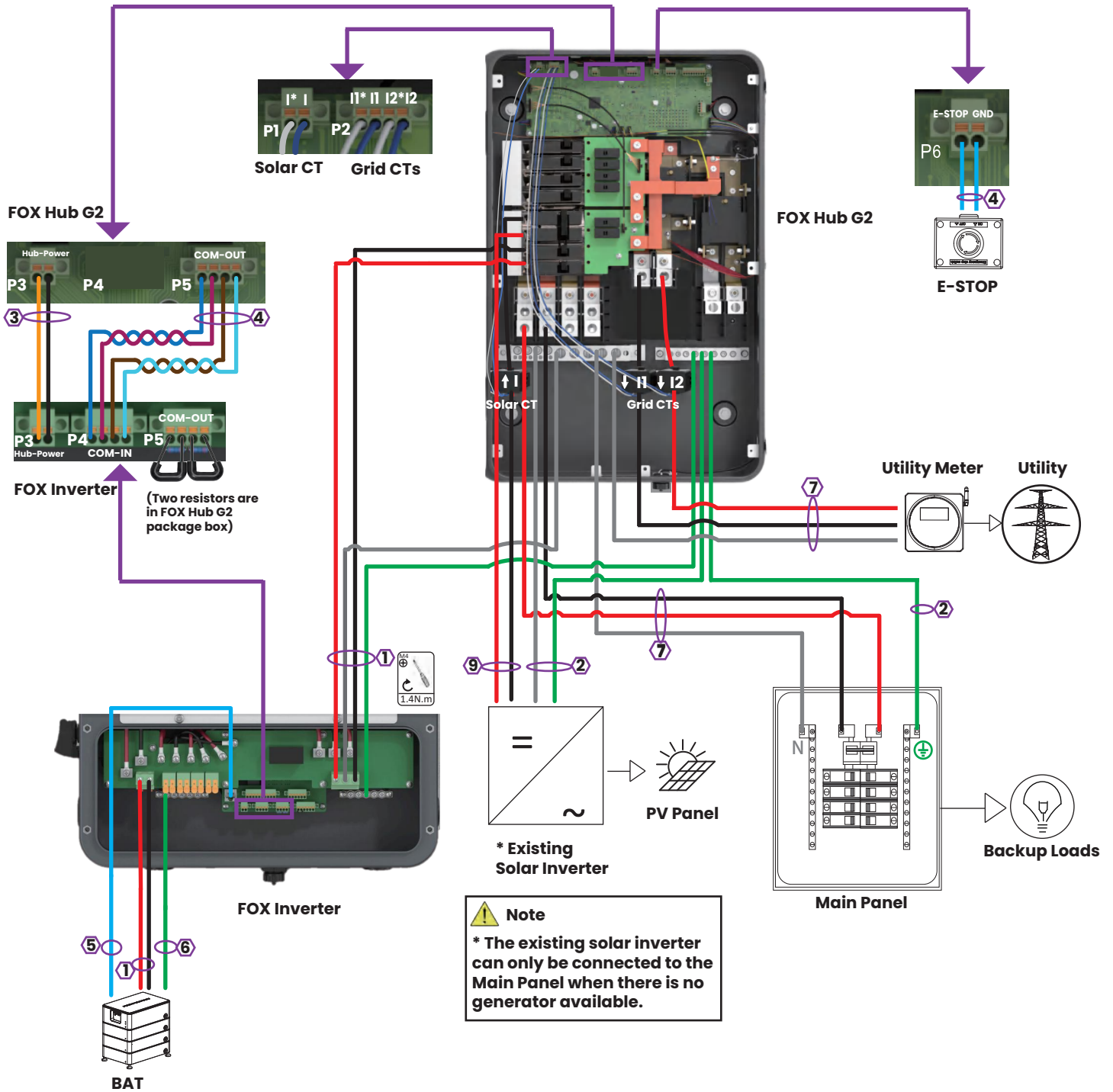

Key

- L1/Negative
- L2/Positive
- Ground
- Neutral

Other Colors: Sensors/Communications

Wire Gauge Guide(copper)		
Label	Input Terminal	Conductor
1	BAT/AC IN/OUT/N/GND	6 AWG
2	AC IN/OUT/N/GND	6-2/0 AWG
3	Power	16 AWG
4	Signal Cable	24-16 AWG
5	Communication Cable	Ethernet Cable
6	MPPT/GND	10 AWG
7	AC IN/OUT/N	6AWG-250 kcmil
8	AC IN/OUT/N	6-4/0 AWG
9	AC IN/OUT	6-1/0 AWG

Fox ESS Three-line Diagram (1 FOX Hub G2+1 INV)

Partial-home Backup (DC Couple) (FOX Hub G2 as Service Panel)

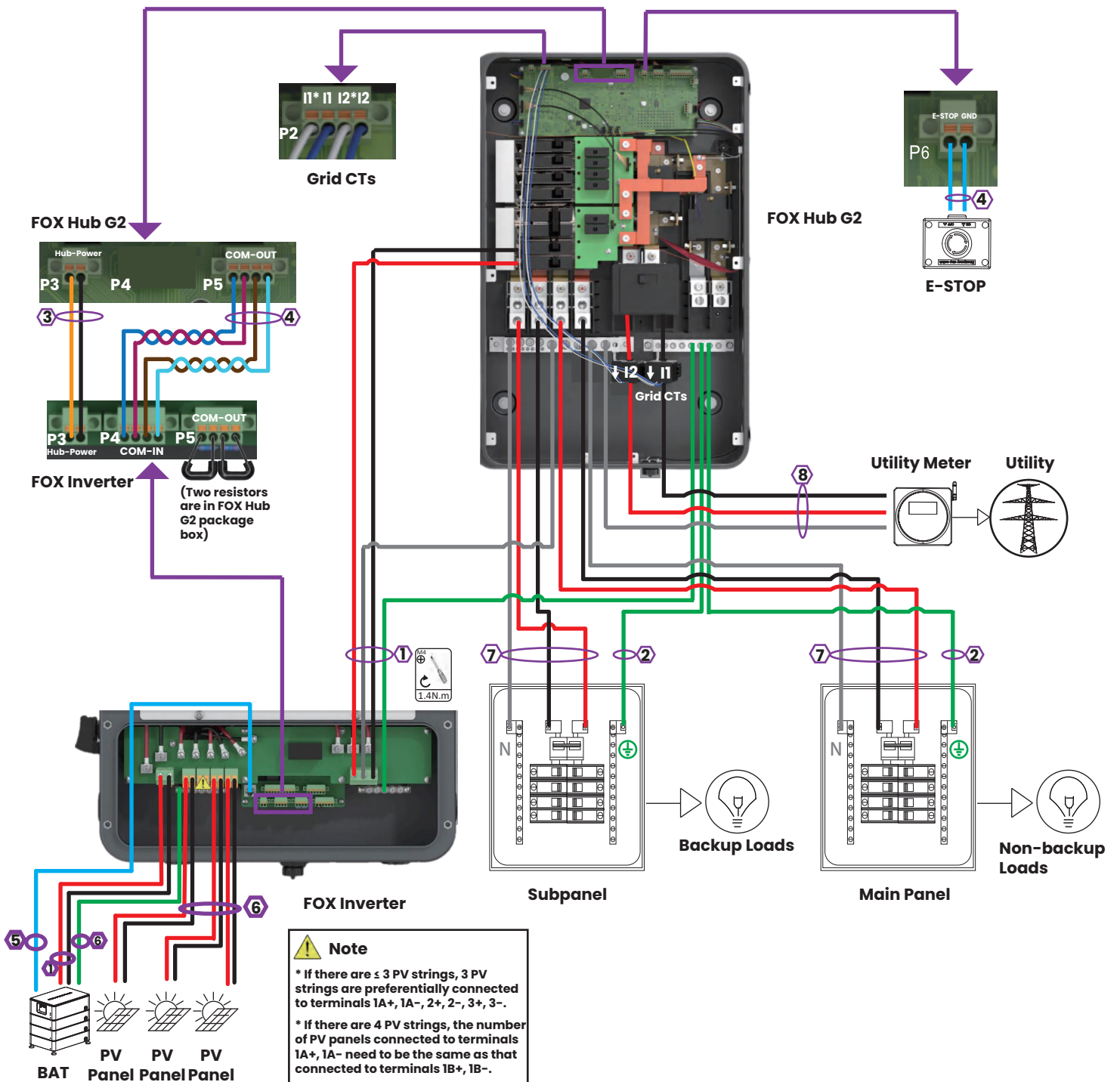

Wire Gauge Guide(copper)		
Label	Input Terminal	Conductor
1	BAT/AC IN/OUT/N/GND	6 AWG
2	AC IN/OUT/N/GND	6-2/0 AWG
3	Power	16 AWG
4	Signal Cable	24-16 AWG
5	Communication Cable	Ethernet Cable
6	MPPT/GND	10 AWG
7	AC IN/OUT/N	6AWG-250 kcmil
8	AC IN/OUT/N	6-4/0 AWG
9	AC IN/OUT	6-1/0 AWG

Key

- L1/Negative
- L2/Positive
- Ground
- Neutral

Other Colors: Sensors/Communications

Fox ESS Three-line Diagram (1 FOX Hub G2+1 INV)

Partial-home Backup (DC Couple) (FOX Hub G2 not as Service Panel)

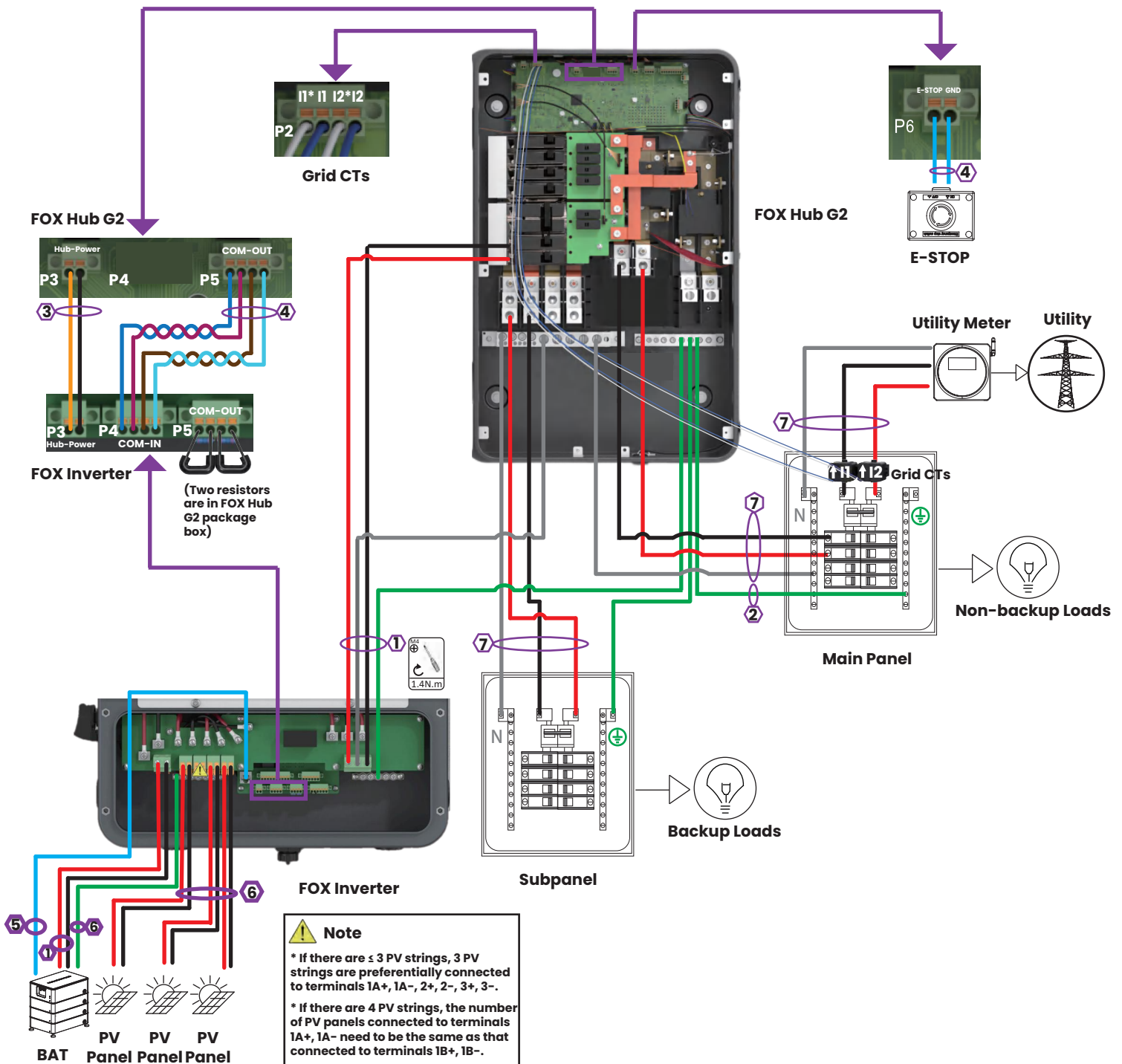

Wire Gauge Guide(copper)		
Label	Input Terminal	Conductor
1	BAT/AC IN/OUT/N/GND	6 AWG
2	AC IN/OUT/N/GND	6-2/0 AWG
3	Power	16 AWG
4	Signal Cable	24-16 AWG
5	Communication Cable	Ethernet Cable
6	MPPT/GND	10 AWG
7	AC IN/OUT/N	6AWG-250 kcmil
8	AC IN/OUT/N	6-4/0 AWG
9	AC IN/OUT	6-1/0 AWG

Key

- L1/Negative
- L2/Positive
- Ground
- Neutral

Other Colors: Sensors/Communications

Fox ESS Three-line Diagram (1 FOX Hub G2+1 INV)

Partial-home Backup (AC Couple) (FOX Hub G2 as Service Panel)

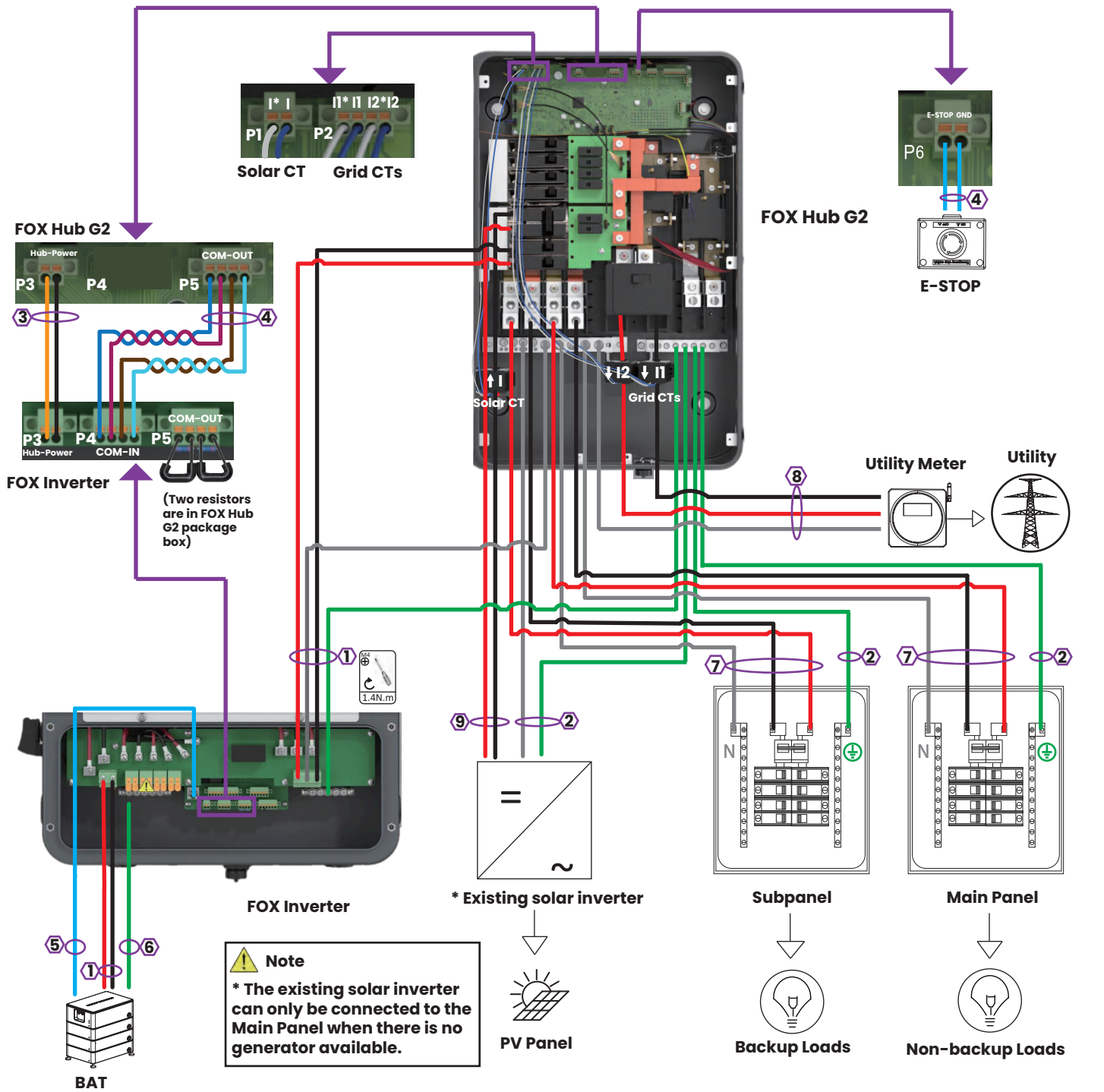

Wire Gauge Guide(copper)		
Label	Input Terminal	Conductor
1	BAT/AC IN/OUT/N/GND	6 AWG
2	AC IN/OUT/N/GND	6-2/0 AWG
3	Power	16 AWG
4	Signal Cable	24-16 AWG
5	Communication Cable	Ethernet Cable
6	MPPT/GND	10 AWG
7	AC IN/OUT/N	6AWG-250 kcmil
8	AC IN/OUT/N	6-4/0 AWG
9	AC IN/OUT	6-1/0 AWG

Key

- L1/Negative
- L2/Positive
- Ground
- Neutral

Other Colors: Sensors/Communications

Fox ESS Three-line Diagram (1 FOX Hub G2+1 INV)

Partial-home Backup (AC Couple) (FOX Hub G2 not as Service Panel)

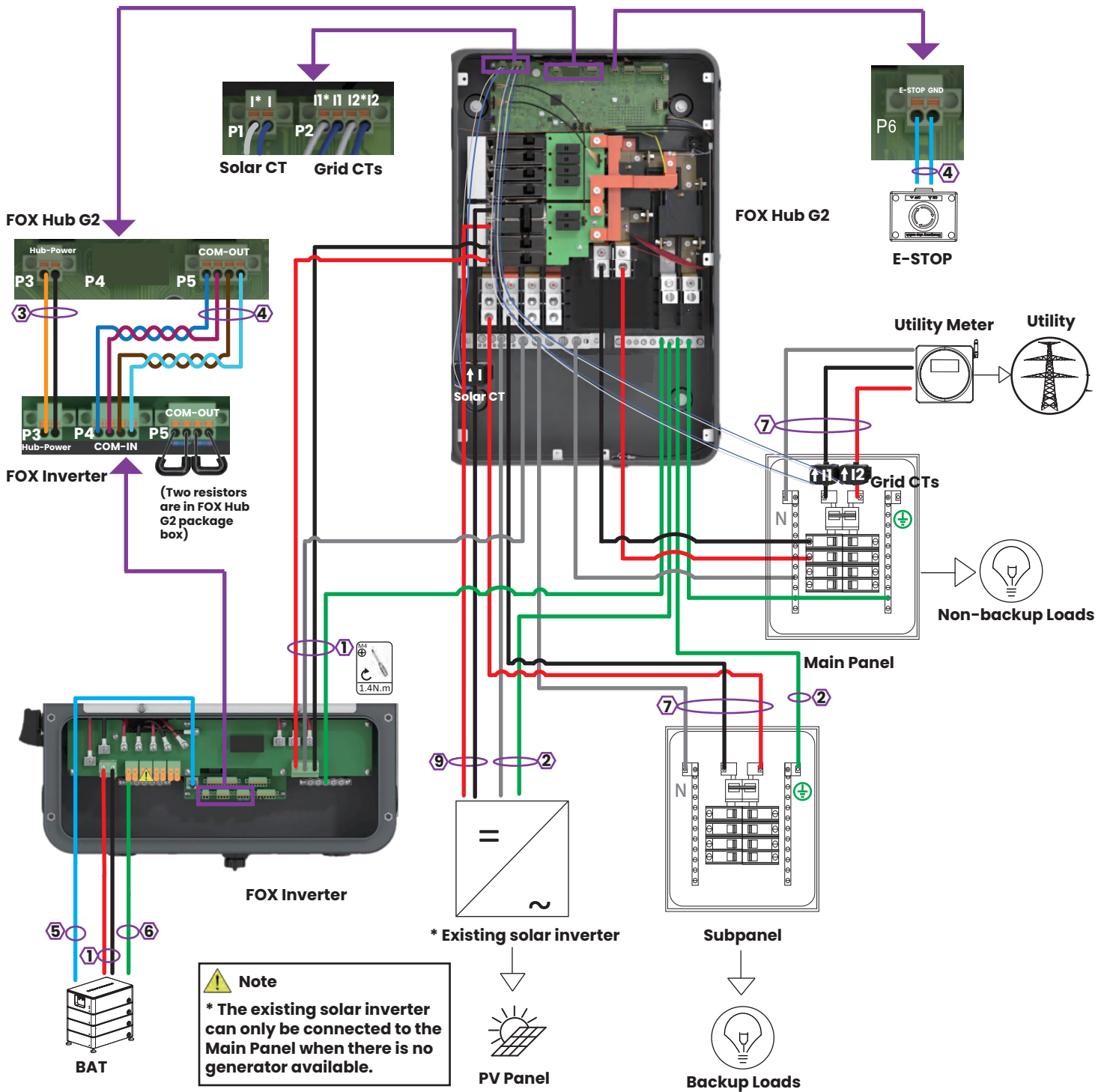

Wire Gauge Guide(copper)		
Label	Input Terminal	Conductor
1	BAT/AC IN/OUT/N/GND	6 AWG
2	AC IN/OUT/N/GND	6-2/0 AWG
3	Power	16 AWG
4	Signal Cable	24-16 AWG
5	Communication Cable	Ethernet Cable
6	MPPT/GND	10 AWG
7	AC IN/OUT/N	6AWG-250 kcmil
8	AC IN/OUT/N	6-4/0 AWG
9	AC IN/OUT	6-1/0 AWG

Key

- L1/Negative
- L2/Positive
- Ground
- Neutral

Other Colors: Sensors/Communications

Fox ESS Three-line Diagram (1 FOX Hub G2+1 INV)

Generator Wiring (Optional)

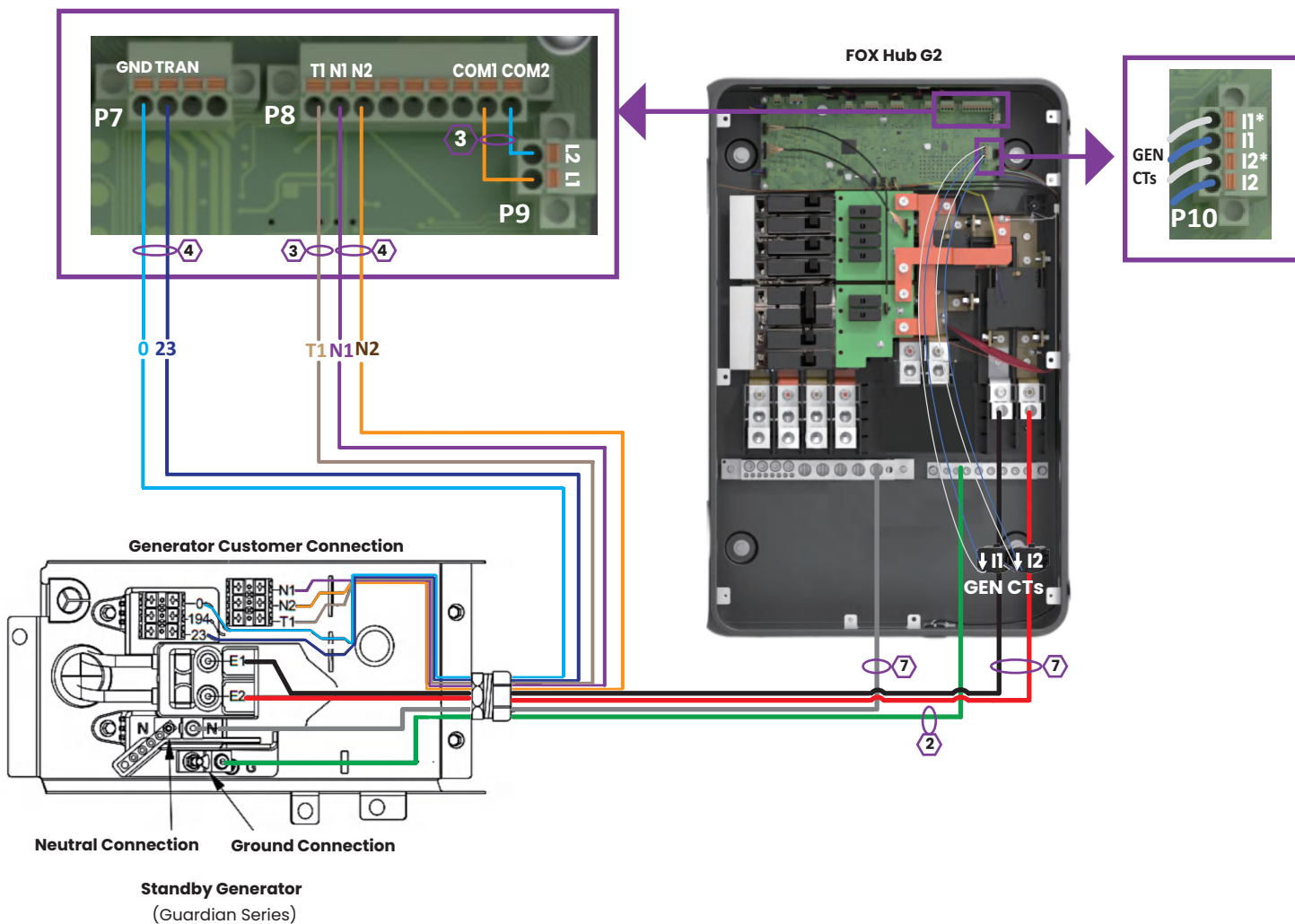

Key

- L1/Negative
- L2/Positive
- Ground
- Neutral

Other Colors: Sensors/Communications

Wire Gauge Guide(copper)		
Label	Input Terminal	Conductor
1	BAT/AC IN/OUT/N/GND	6 AWG
2	AC IN/OUT/N/GND	6-2/0 AWG
3	Power	16 AWG
4	Signal Cable	24-16 AWG
5	Communication Cable	Ethernet Cable
6	MPPT	10 AWG
7	AC IN/OUT/N	6AWG-250 kcmil
8	AC IN/OUT/N	6-4/0 AWG
9	AC IN/OUT	6-1/0 AWG

Fox ESS Three-line Diagram (1 FOX Hub G2+1 INV)

Smart Loads Wiring (Optional)

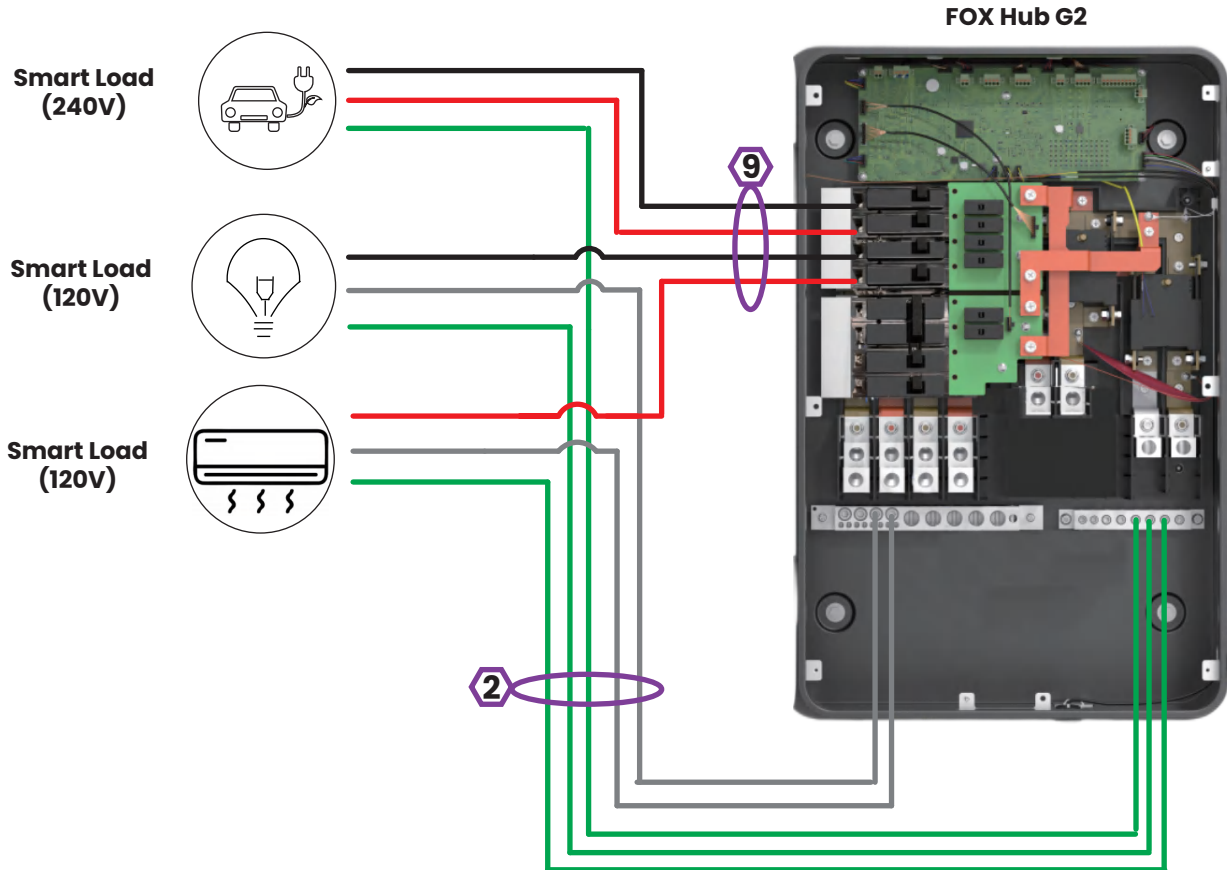

Key

- L1/Negative
- L2/Positive
- Ground
- Neutral

Other Colors: Sensors/
Communications

Wire Gauge Guide(copper)		
Label	Input Terminal	Conductor
1	BAT/AC IN/OUT/N/GND	6 AWG
2	AC IN/OUT/N/GND	6-2/0 AWG
3	Power	16 AWG
4	Signal Cable	24-16 AWG
5	Communication Cable	Ethernet Cable
6	MPPT	10 AWG
7	AC IN/OUT/N	6AWG-250 kcmil
8	AC IN/OUT/N	6-4/0 AWG
9	AC IN/OUT	6-1/0 AWG

7 Appendix 2: Fox ESS Three-line Diagram (1 FOX Hub G2+Parallel INVs)

Whole-home Backup (DC Couple)

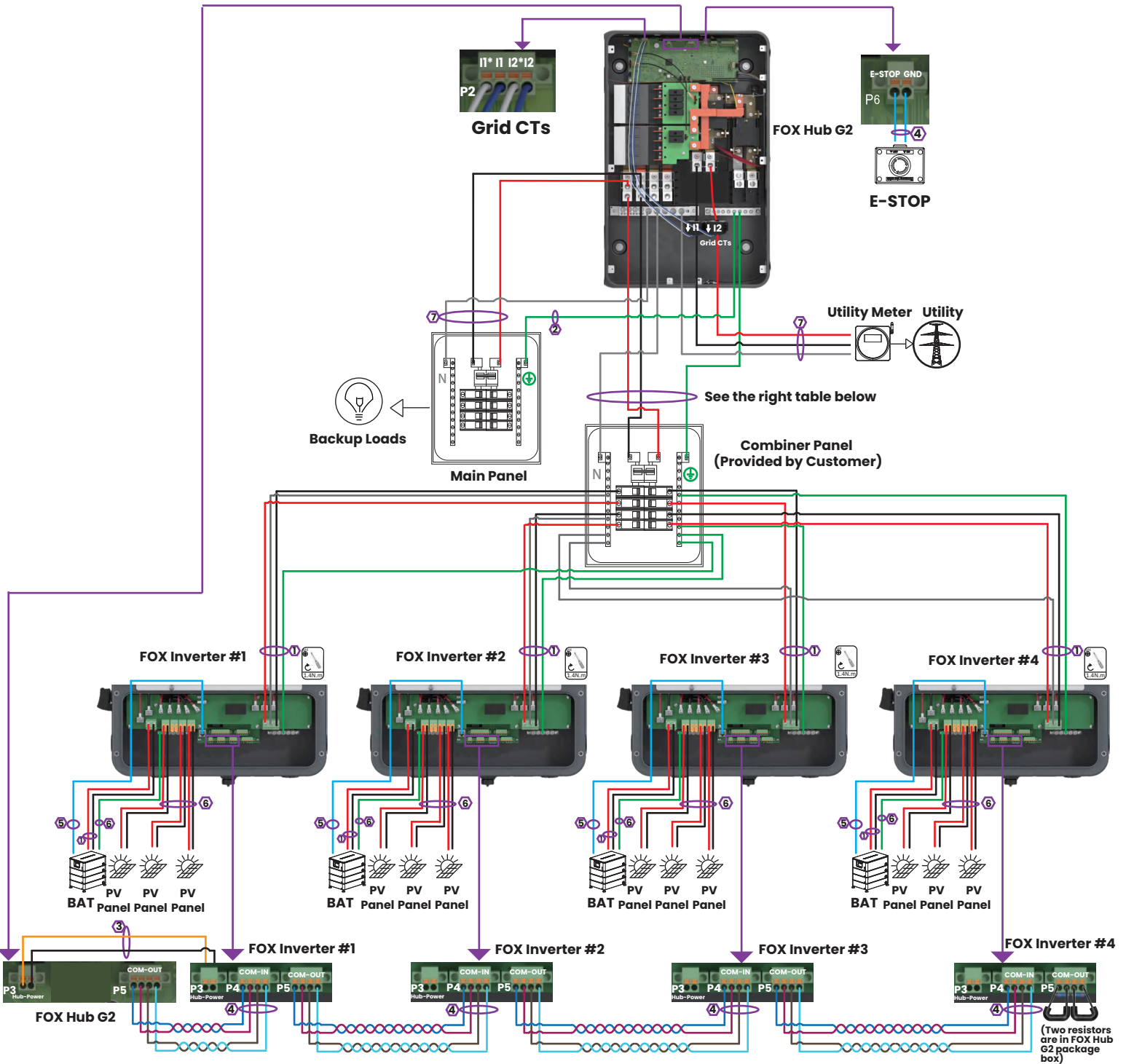

Wire Gauge Guide(copper)		
Label	Input Terminal	Conductor
1	BAT/AC IN/OUT/N/GND	6 AWG
2	AC IN/OUT/N/GND	6-2/0 AWG
3	Power	16 AWG
4	Signal Cable	24-16 AWG
5	Communication Cable	Ethernet Cable
6	MPPT/GND	10 AWG
7	AC IN/OUT/N	6AWG-250 kcmil
8	AC IN/OUT/N	6-4/0 AWG
9	AC IN/OUT	6-1/0 AWG

Key

- L1/Negative
- L2/Positive
- Ground
- Neutral

Other Colors: Sensors/Communications

⚠ Note

* If there are ≤ 3 PV strings, 3 PV strings are preferentially connected to terminals 1A+, 1A-, 2+, 2-, 3+, 3-.

* If there are 4 PV strings, the number of PV panels connected to terminals 1A+, 1A- need to be the same as that connected to terminals 1B+, 1B-.

No. of Parellel Inverters	Minimum Wire Gauge (Combiner Panel-FOX Hub G2)
2 Inverters	2 AWG
3 Inverters	2/0 AWG
4 Inverters	4/0 AWG

Fox ESS Three-line Diagram (1 FOX Hub G2+Parallel INVs)

Whole-home Backup (AC Couple)

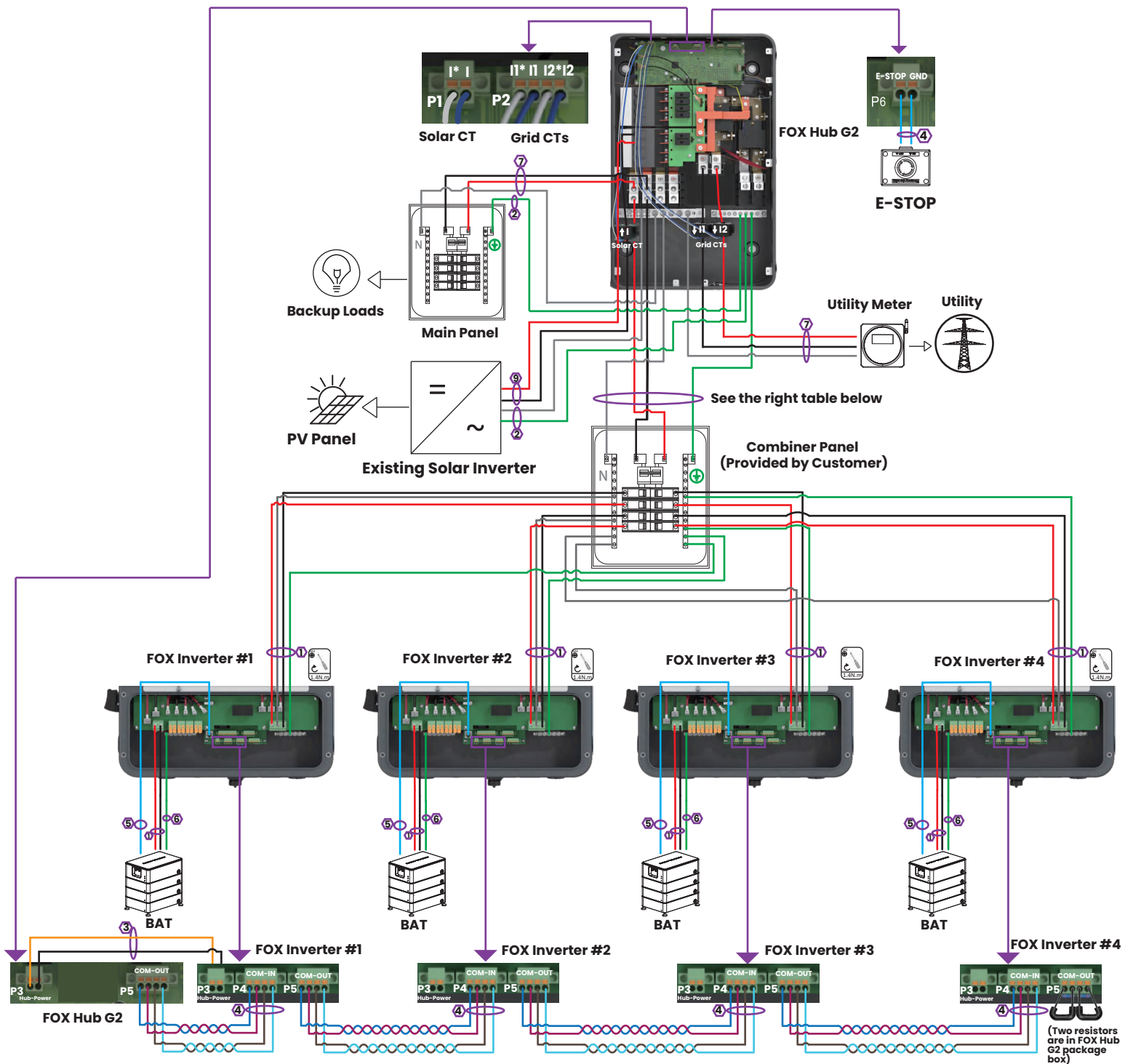

Key

- L1/Negative
- L2/Positive
- Ground
- Neutral
- Other Colors: Sensors/Communications

Wire Gauge Guide(copper)		
Label	Input Terminal	Conductor
1	BAT/AC IN/OUT/N/GND	6 AWG
2	AC IN/OUT/N/GND	6-2/0 AWG
3	Power	16 AWG
4	Signal Cable	24-16 AWG
5	Communication Cable	Ethernet Cable
6	MPPT/GND	10 AWG
7	AC IN/OUT/N	6AWG-250 kcmil
8	AC IN/OUT/N	6-4/0 AWG
9	AC IN/OUT	6-1/0 AWG

No. of Parellel Inverters	Minimum Wire Gauge (Cominer Panel-FOX Hub G2)
2 Inverters	2 AWG
3 Inverters	2/0 AWG
4 Inverters	4/0 AWG

Fox ESS Three-line Diagram (1 FOX Hub G2+Parallel INVs)

Partial-home Backup (DC Couple) (FOX Hub G2 as Service Panel)

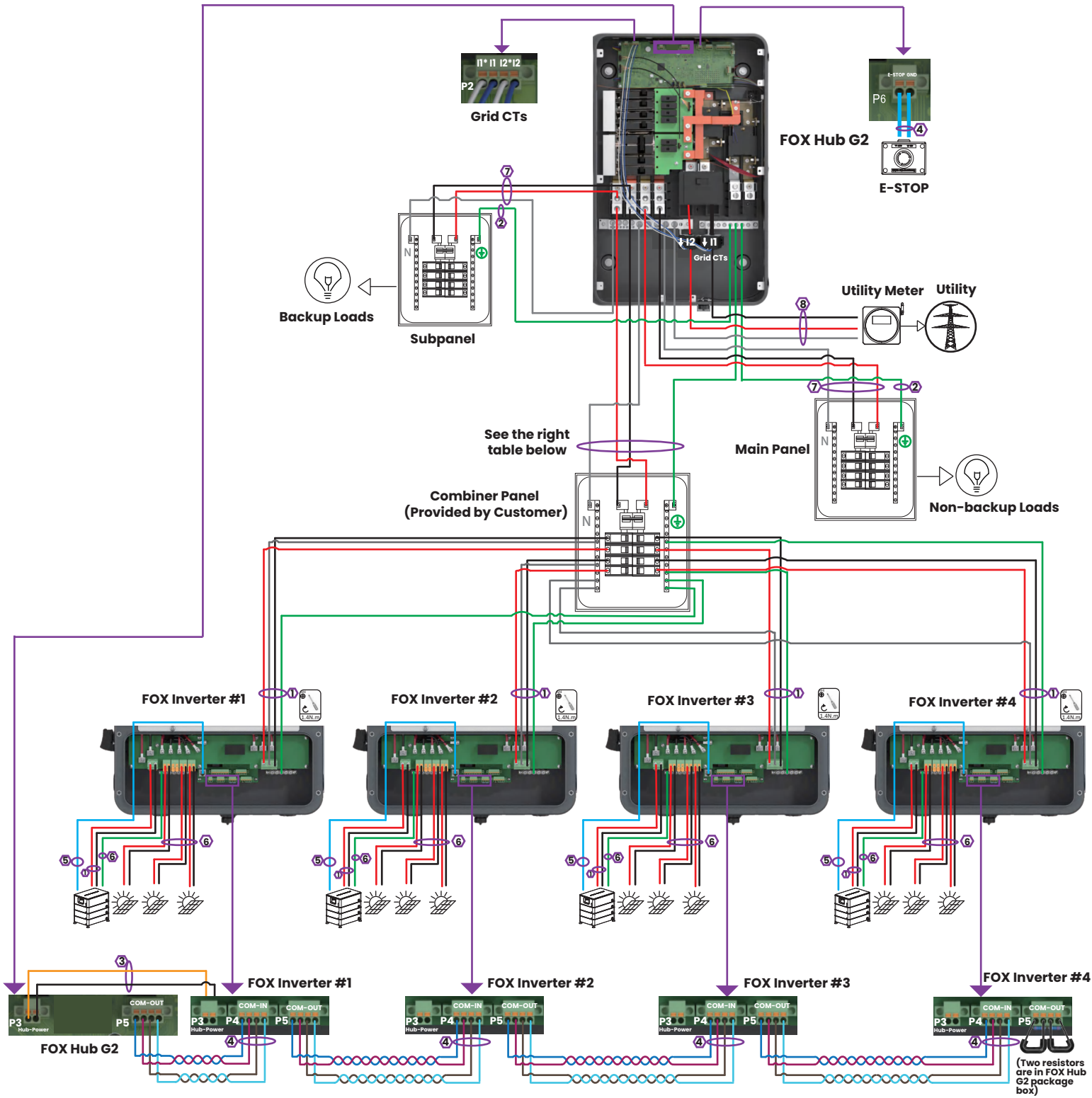

Wire Gauge Guide(copper)		
Label	Input Terminal	Conductor
1	BAT/AC IN/OUT/N/GND	6 AWG
2	AC IN/OUT/N/GND	6-2/0 AWG
3	Power	16 AWG
4	Signal Cable	24-16 AWG
5	Communication Cable	Ethernet Cable
6	MPPT/GND	10 AWG
7	AC IN/OUT/N	6AWG-250 kcmil
8	AC IN/OUT/N	6-4/0 AWG
9	AC IN/OUT	6-1/0 AWG

Key

- L1/Negative
- L2/Positive
- Ground
- Neutral

Other Colors: Sensors/Communications

⚠ Note

* If there are ≤ 3 PV strings, 3 PV strings are preferentially connected to terminals 1A+, 1A-, 2+, 2-, 3+, 3-.

* If there are 4 PV strings, the number of PV panels connected to terminals 1A+, 1A- need to be the same as that connected to terminals 1B+, 1B-.

No. of Parallel Inverters	Minimum Wire Gauge (Combiner Panel-FOX Hub G2)
2 Inverters	2 AWG
3 Inverters	2/0 AWG
4 Inverters	4/0 AWG

Fox ESS Three-line Diagram (1 FOX Hub G2+Parallel INVs)

Partial-home Backup (DC Couple) (FOX Hub G2 not as Service Panel)

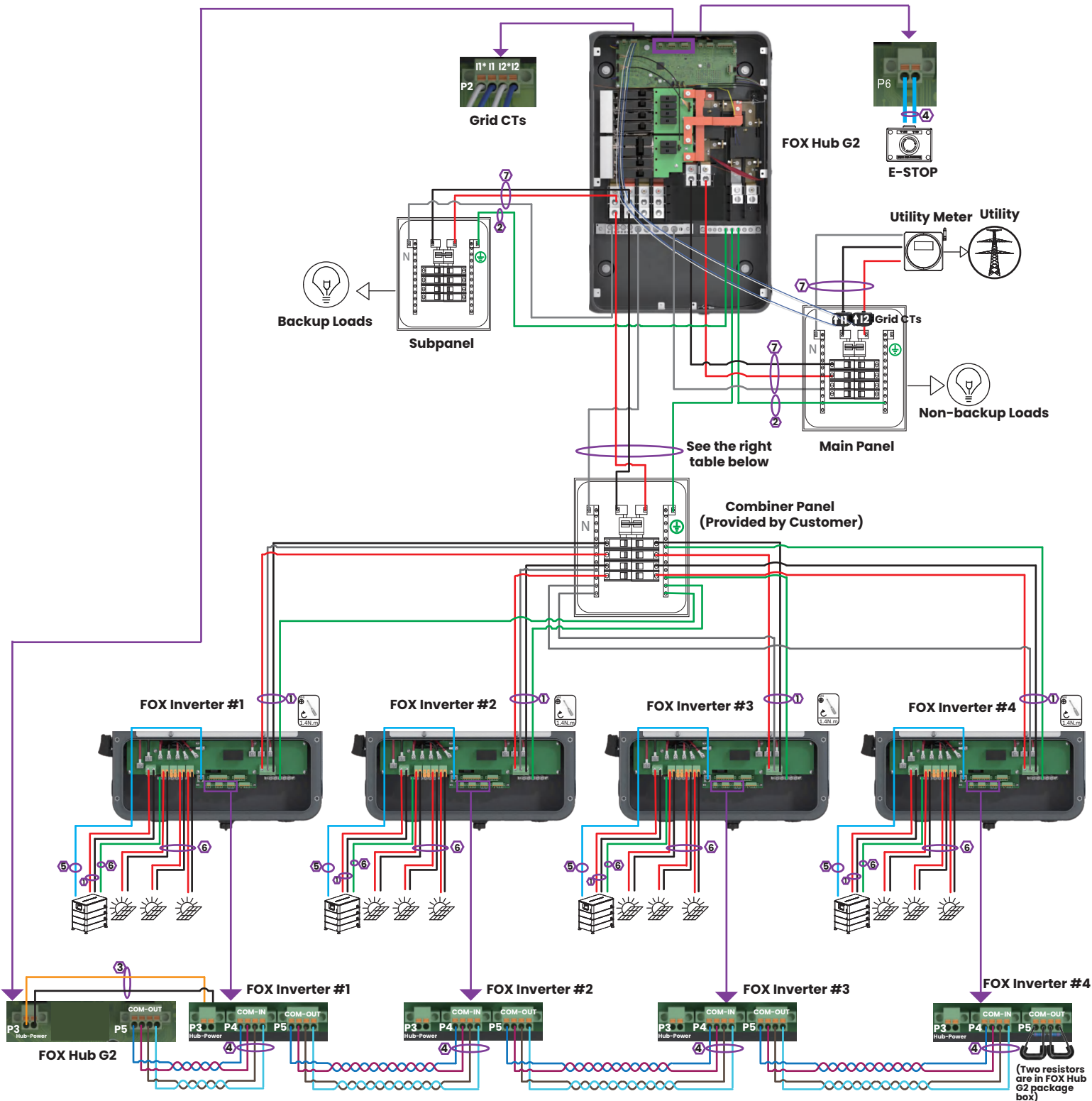

Key	
●	L1/Negative
●	L2/Positive
●	Ground
●	Neutral
●	Other Colors: Sensors/Communications

Wire Gauge Guide(copper)		
Label	Input Terminal	Conductor
1	BAT/AC IN/OUT/N/GND	6 AWG
2	AC IN/OUT/N/GND	6-2/0 AWG
3	Power	16 AWG
4	Signal Cable	24-16 AWG
5	Communication Cable	Ethernet Cable
6	MPPT/GND	10 AWG
7	AC IN/OUT/N	6AWG-250 kcmil
8	AC IN/OUT/N	6-4/0 AWG
9	AC IN/OUT	6-1/0 AWG

⚠ Note

* If there are ≤ 3 PV strings, 3 PV strings are preferentially connected to terminals 1A+, 1A-, 2+, 2-, 3+, 3-.

* If there are 4 PV strings, the number of PV panels connected to terminals 1A+, 1A- need to be the same as that connected to terminals 1B+, 1B-.

No. of Parellel Inverters	Minimum Wire Gauge (Combiner Panel-FOX Hub G2)
2 Inverters	2 AWG
3 Inverters	2/0 AWG
4 Inverters	4/0 AWG

Fox ESS Three-line Diagram (1 FOX Hub G2+Parallel INVs)

Partial-home Backup (AC Couple) (FOX Hub G2 as Service Panel)

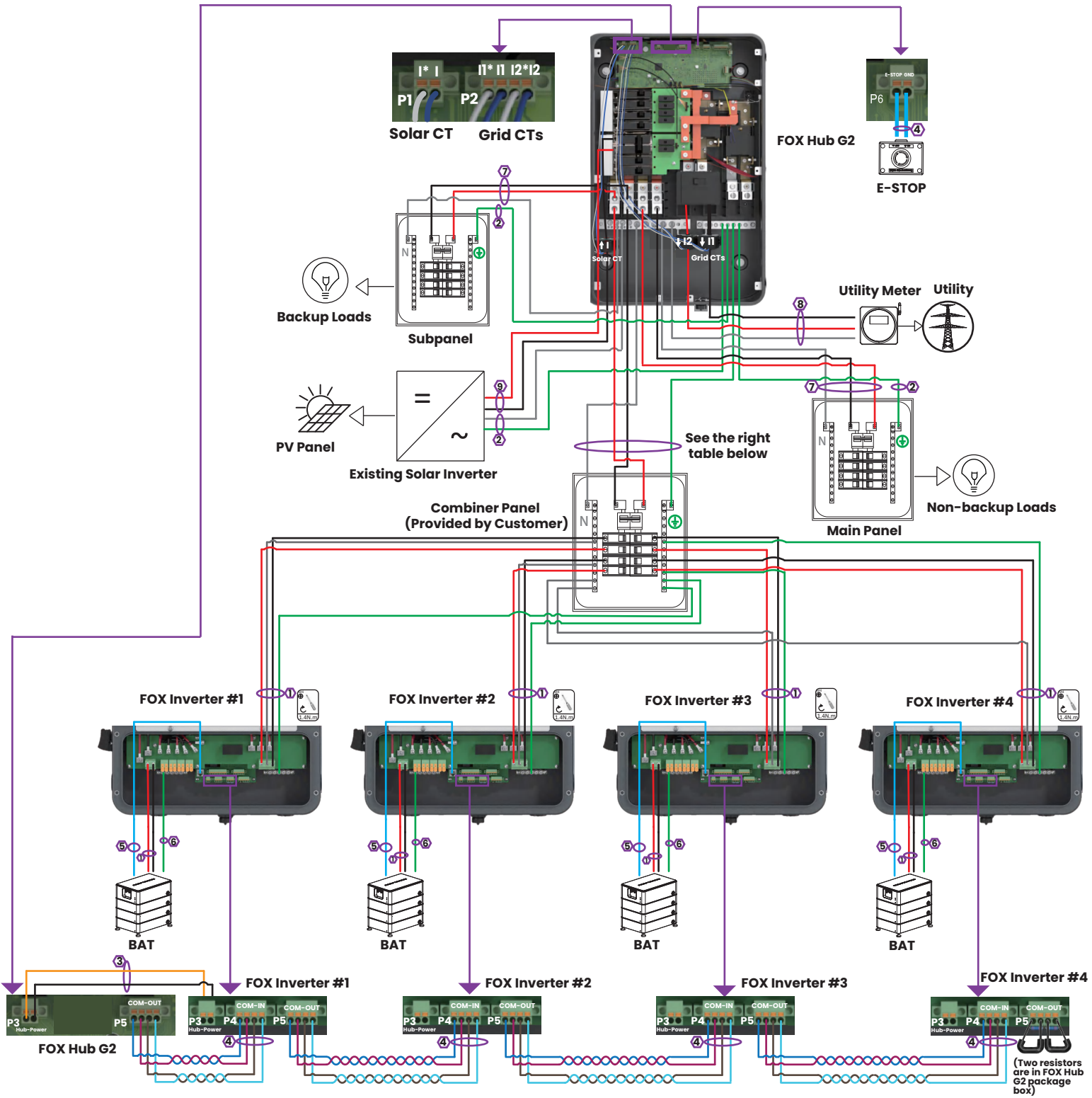

Key

- L1/Negative
- L2/Positive
- Ground
- Neutral

Other Colors: Sensors/Communications

Wire Gauge Guide (copper)		
Label	Input Terminal	Conductor
1	BAT/AC IN/OUT/N/GND	6 AWG
2	AC IN/OUT/N/GND	6-2/0 AWG
3	Power	16 AWG
4	Signal Cable	24-16 AWG
5	Communication Cable	Ethernet Cable
6	MPPT/GND	10 AWG
7	AC IN/OUT/N	6AWG-250 kcmil
8	AC IN/OUT/N	6-4/0 AWG
9	AC IN/OUT	6-1/0 AWG

No. of Parallel Inverters	Minimum Wire Gauge (Combiner Panel-FOX Hub G2)
2 Inverters	2 AWG
3 Inverters	2/0 AWG
4 Inverters	4/0 AWG

Fox ESS Three-line Diagram (1 FOX Hub G2+Parallel INVs)

Partial-home Backup (AC Couple) (FOX Hub G2 not as Service Panel)

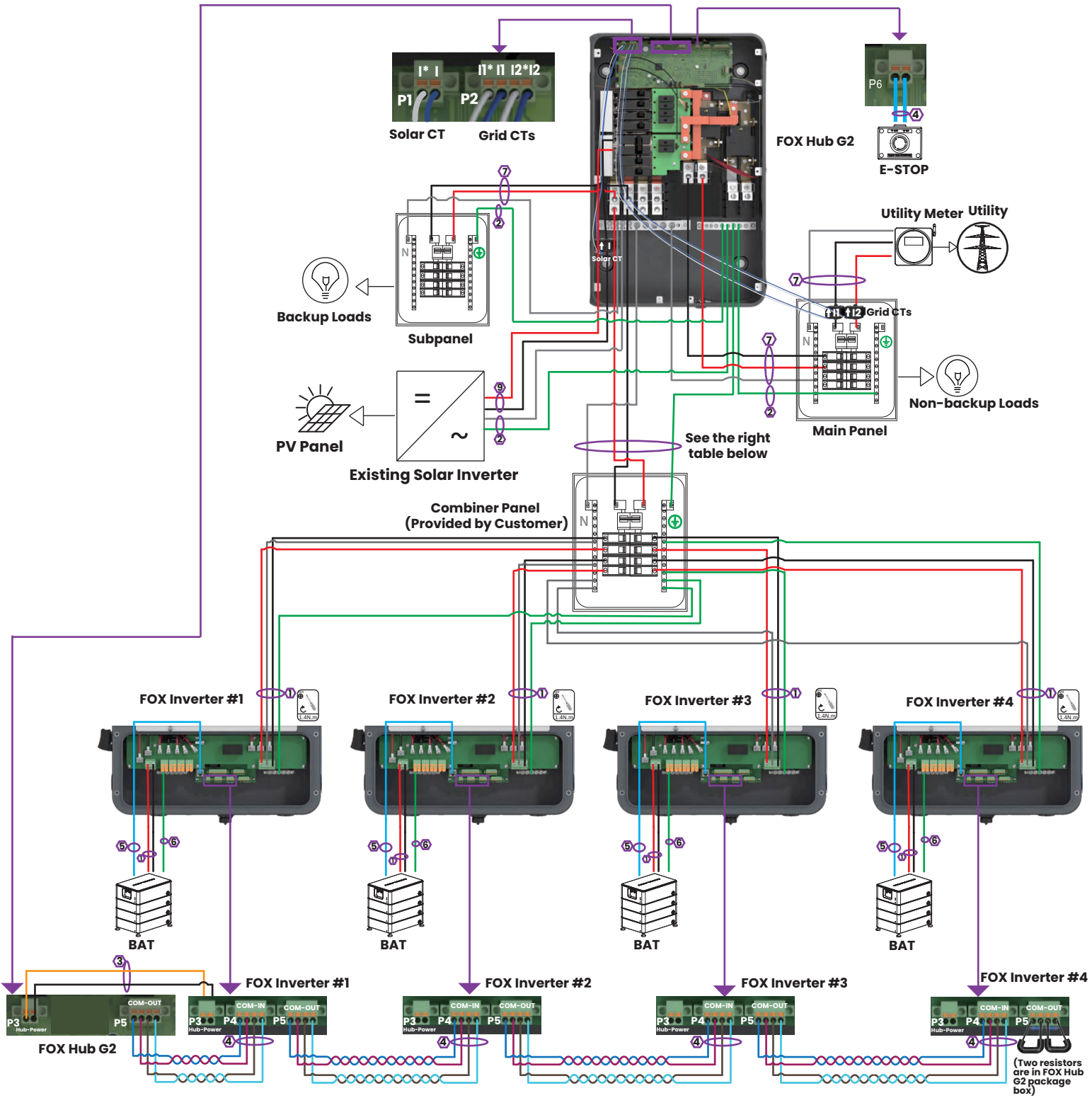

Wire Gauge Guide (copper)

Label	Input Terminal	Conductor
1	BAT/AC IN/OUT/N/GND	6 AWG
2	AC IN/OUT/N/GND	6-2/0 AWG
3	Power	16 AWG
4	Signal Cable	24-16 AWG
5	Communication Cable	Ethernet Cable
6	MPPT/GND	10 AWG
7	AC IN/OUT/N	6AWG-250 kcmil
8	AC IN/OUT/N	6-4/0 AWG
9	AC IN/OUT	6-1/0 AWG

Key

- L1/Negative
- L2/Positive
- Ground
- Neutral
- Other Colors: Sensors/Communications

No. of Parallel Inverters	Minimum Wire Gauge (Combiner Panel-FOX Hub G2)
2 Inverters	2 AWG
3 Inverters	2/0 AWG
4 Inverters	4/0 AWG

(Two resistors are in FOX Hub G2 package box)

Fox ESS Three-line Diagram (1 FOX Hub G2+Parallel INVs)

Generator Wiring (Optional)

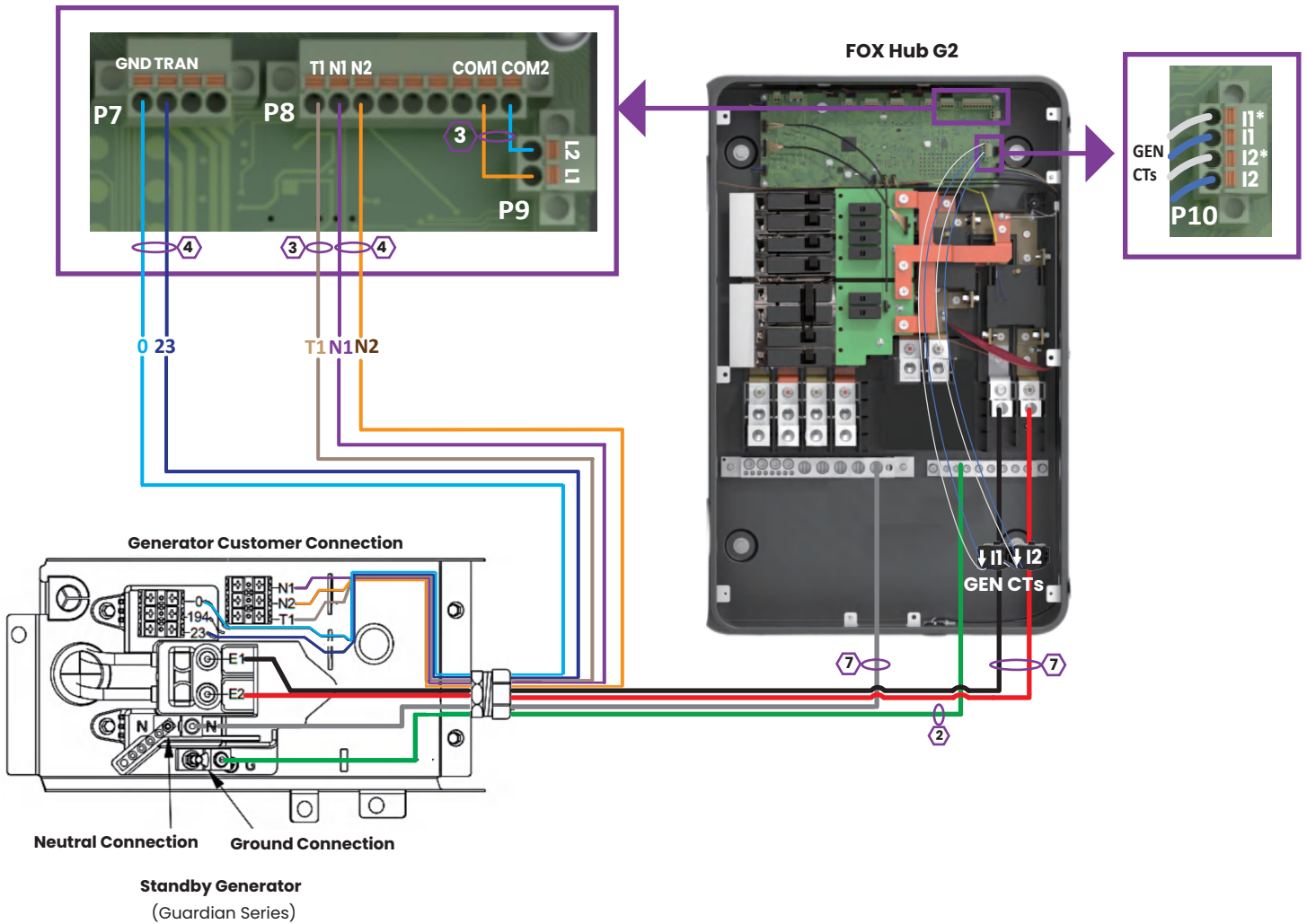

Wire Gauge Guide(copper)		
Label	Input Terminal	Conductor
1	BAT/AC IN/OUT/N/GND	6 AWG
2	AC IN/OUT/N/GND	6-2/0 AWG
3	Power	16 AWG
4	Signal Cable	24-16 AWG
5	Communication Cable	Ethernet Cable
6	MPPT	10 AWG
7	AC IN/OUT/N	6AWG-250 kcmil
8	AC IN/OUT/N	6-4/0 AWG
9	AC IN/OUT	6-1/0 AWG

Fox ESS Three-line Diagram (1 FOX Hub G2+Parallel INVs)

Smart Loads Wiring (Optional)

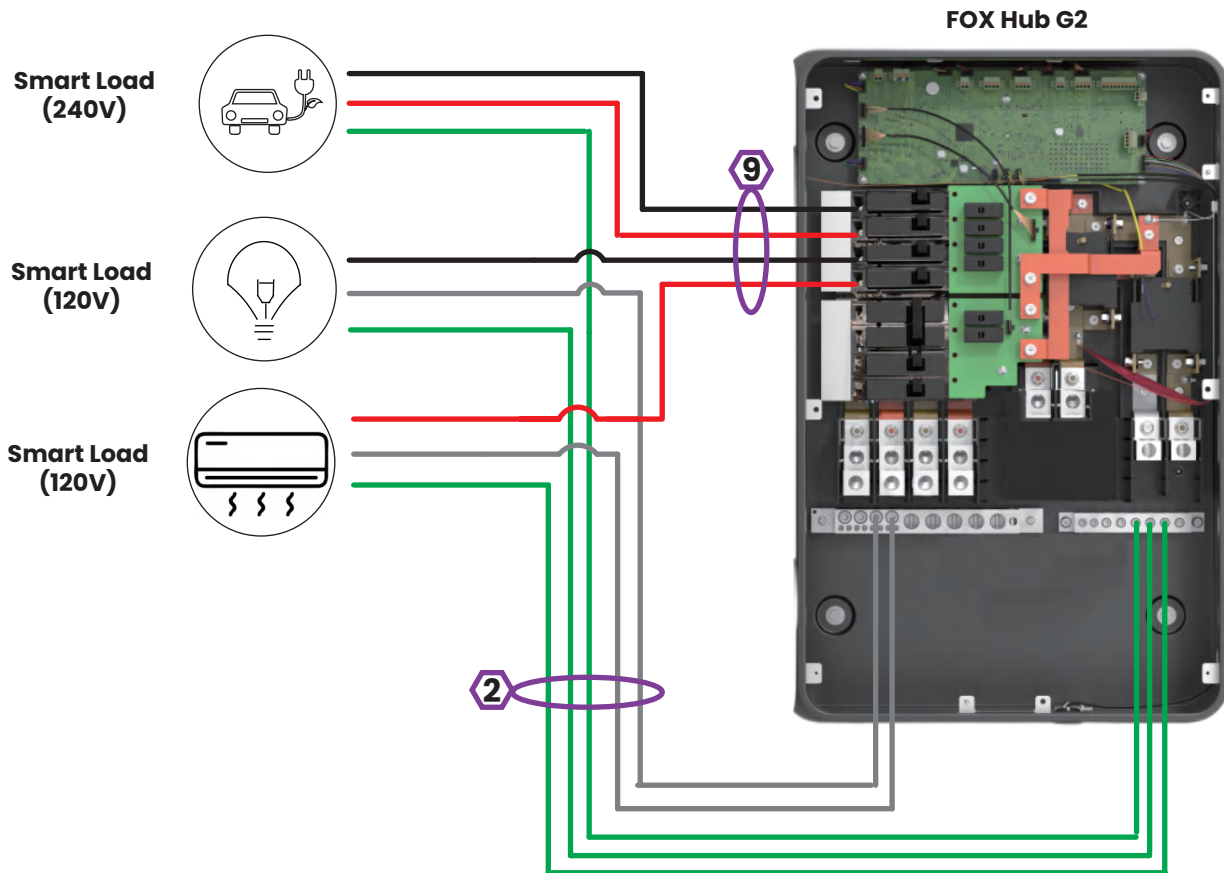

Key

- L1/Negative
- L2/Positive
- Ground
- Neutral

Other Colors: Sensors/Communications

Wire Gauge Guide(copper)		
Label	Input Terminal	Conductor
1	BAT/AC IN/OUT/N/GND	6 AWG
2	AC IN/OUT/N/GND	6-2/0 AWG
3	Power	16 AWG
4	Signal Cable	24-16 AWG
5	Communication Cable	Ethernet Cable
6	MPPT	10 AWG
7	AC IN/OUT/N	6AWG-250 kcmil
8	AC IN/OUT/N	6-4/0 AWG
9	AC IN/OUT	6-1/0 AWG

The copyright of this manual belongs to Fox ESS CO., LTD. Any corporation or individual should not plagiarize, partially or fully copy (including software, etc.), and no reproduction or distribution of it in any form or by any means is permitted.

All rights reserved.

Fox ESS CO., LTD.

Add: No. 939, Jinhai Third Road, New Airport Industry Area, Longwan District, Wenzhou, Zhejiang Province, China

Tel: 86-510-68092998

WWW.FOX-ESS.COM